

STEREO RECEIVER

R-2000

SERVICE MANUAL

FRONT PANEL

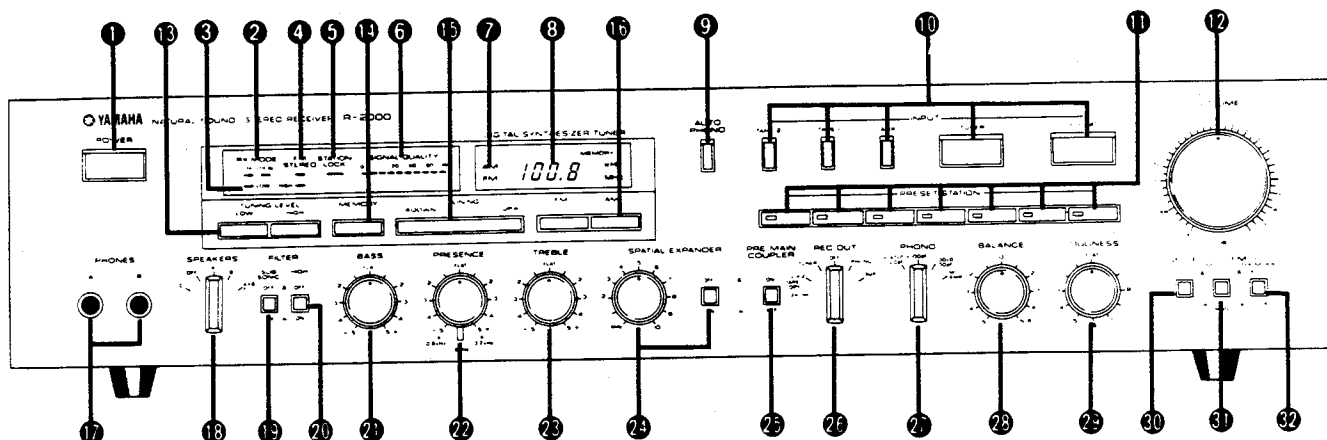

- | | |
|-----------------------------|-----------------------------|
| 1 POWER SWITCH | 17 PHONES JACKS |
| 2 RX MODE INDICATOR | 18 SPEAKERS SELECTOR |
| 3 TUNING LEVEL INDICATOR | 19 SUBSONIC FILTER SWITCH |
| 4 FM STEREO INDICATOR | 20 HIGH FILTER SWITCH |
| 5 STATION LOCK INDICATOR | 21 BASS CONTROL |
| 6 SIGNAL QUALITY INDICATOR | 22 PRESENCE CONTROL |
| 7 AM/FM INDICATOR | 23 TREBLE CONTROL |
| 8 DIGITAL FREQUENCY READOUT | 24 SPATIAL EXPANDER CONTROL |
| 9 AUTO PHONO SWITCH | 25 PRE-MAIN COUPLER SWITCH |
| 10 INPUT SELECTOR BUTTONS | 26 REC OUT SELECTOR |
| 11 PRESET STATION BUTTONS | 27 PHONO SELECTOR |
| 12 VOLUME CONTROL | 28 BALANCE CONTROL |
| 13 TUNING LEVEL BUTTONS | 29 LOUDNESS CONTROL |
| 14 MEMORY BUTTON | 30 MODE SWITCH |
| 15 TUNING BUTTON | 31 FM MUTING SWITCH |
| 16 BAND SELECT BUTTONS | 32 RX MODE SWITCH |

CONTENTS

REAR PANEL	1	SPECIFICATION	8
INTERNAL VIEW	2	BLOCK DIAGRAM	9
DISASSEMBLY PROCEDURES	2	WIRING DIAGRAM	10
MEASUREMENT AND ADJUSTMENT	5	SCHEMATIC DIAGRAM	11

004433

SINCE 1887



YAMAHA

NIPPON GAKKI CO., LTD. HAMAMATSU, JAPAN

REAR PANEL

▼ U.S.A. & CANADIAN MODELS

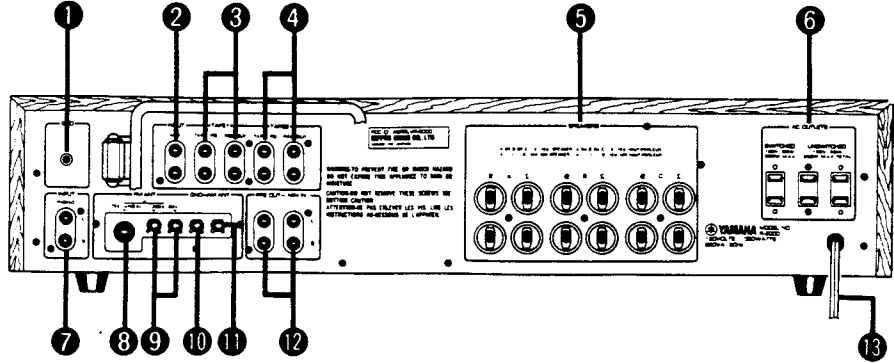

▼ GENERAL MODEL

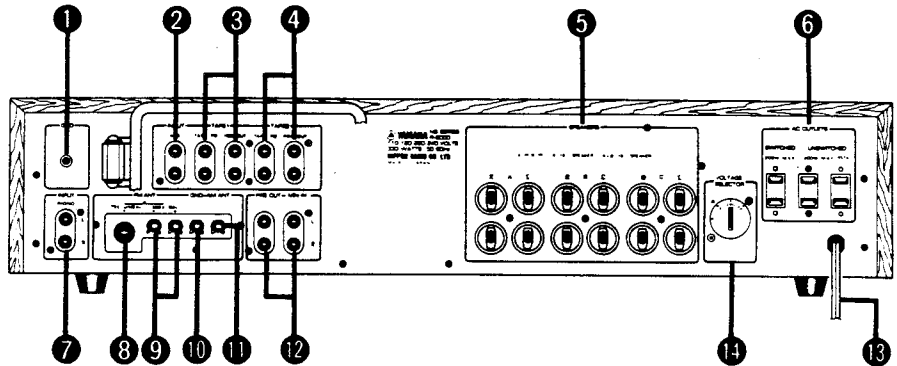

▼ BRITISH & AUSTRALIAN MODELS

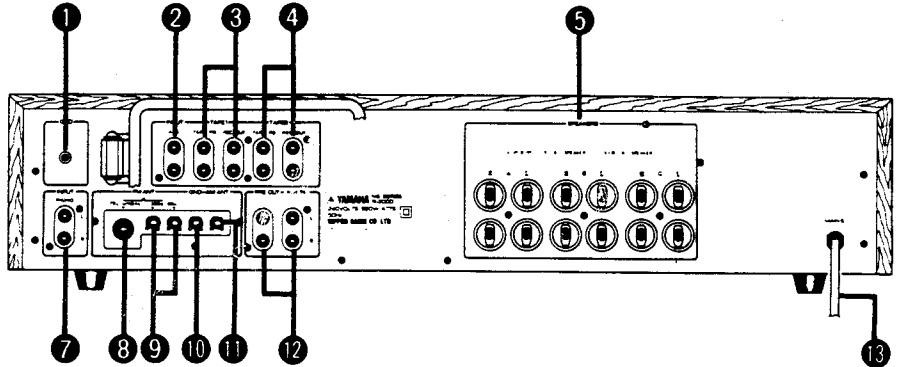

▼ NORTH EUROPEAN MODEL

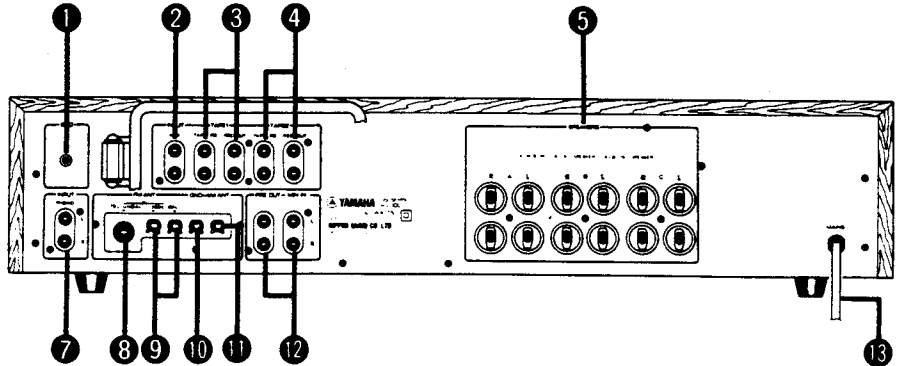

- ① GROUND TERMINAL
- ② AUX INPUT JACKS
- ③ TAPE 1 PB/REC JACKS
- ④ TAPE 2 PB/REC JACKS
- ⑤ SPEAKERS TERMINAL

- ⑥ AC OUTLETS
- ⑦ PHONO INPUT JACKS
- ⑧ FM ANTENNA TERMINAL (75Ω)
- ⑨ FM ANTENNA TERMINAL (300Ω)
- ⑩ AM ANTENNA TERMINAL
- ⑪ PRE OUT/MAIN IN JACKS
- ⑫ POWER CORD
- ⑬ VOLTAGE SELECTOR

- ⑬ VOLTAGE SELECTOR

INTERNAL VIEW

TOP VIEW

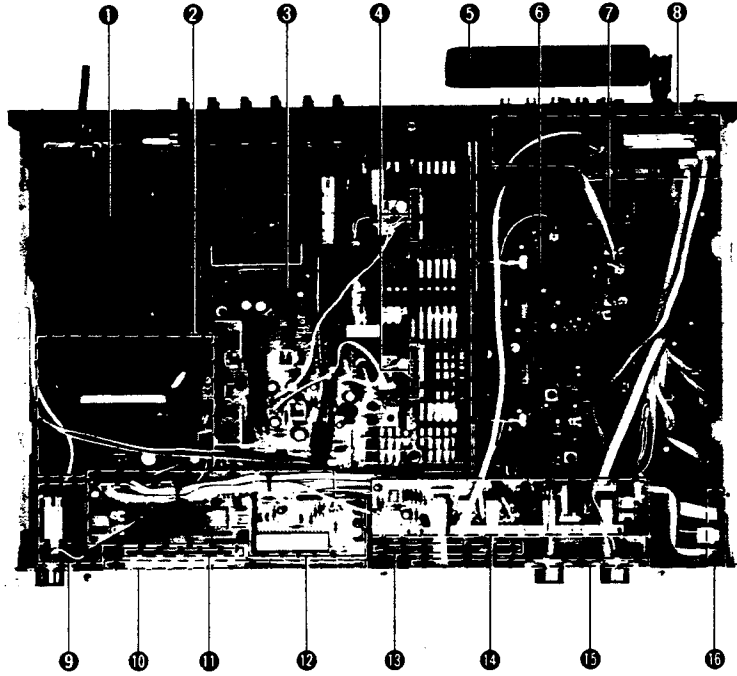

- ① POWER TRANSFORMER GA6465 (U)
GA6466 (C)
GA6468 (R)
GA6467 (G)
GA6469 (A, B)
- ② ELECTROLYTIC CAPACITOR CIRCUIT BOARD
(Power supply)
- ③ MAIN CIRCUIT BOARD [1]
- ④ I AMP CIRCUIT BOARD
- ⑤ AM LOOP ANTENNA
- ⑥ TUNER CIRCUIT BOARD
- ⑦ FRONT END PACK PK101
- ⑧ MAIN CIRCUIT BOARD [3] (Pin Jacks)
- ⑨ CONTROL CIRCUIT BOARD [6] (Phones Jacks)
- ⑩ CONTROL CIRCUIT BOARD [2]
- ⑪ CONTROL CIRCUIT BOARD [4]
- ⑫ CONTROL CIRCUIT BOARD [1]
- ⑬ MAIN CIRCUIT BOARD [4]
- ⑭ MAIN CIRCUIT BOARD [2]
- ⑮ CONTROL CIRCUIT BOARD [3]
- ⑯ CONTROL CIRCUIT BOARD [5]

DISASSEMBLY PROCEDURES

1. Top Cover Removal

Remove the screws ① and ② in photo 1 from both right and left sides, then remove the top cover.

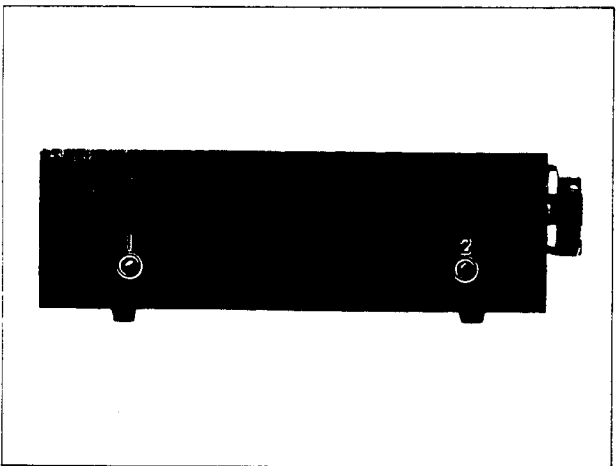

Photo 1

2. Bottom Cover Removal

Remove the screws ① to ⑬ in photo 2 and then remove the bottom cover.

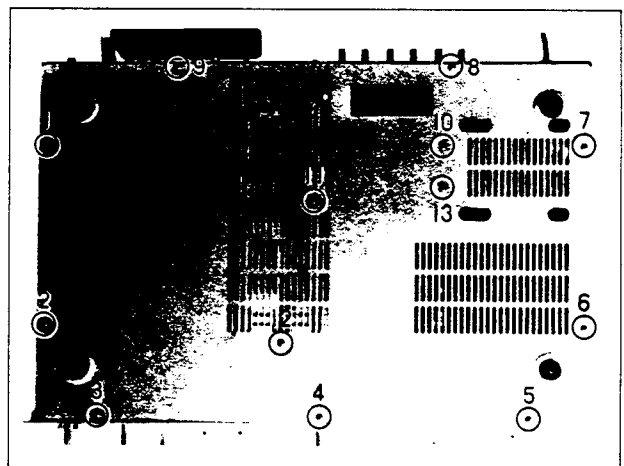

Photo 2

3. Front Panel Removal

- a. Loosen the set screws of SPEAKERS, REC OUT, PRESENCE and PHONO knobs with a 1.5 mm hexagon wrench, then pull out each knob.
 - b. Remove the screws ① to ③ in photo 3 and remove the front panel.
- * Remove the screws ③ to ⑤ in photo 2 when the front panel is removed.

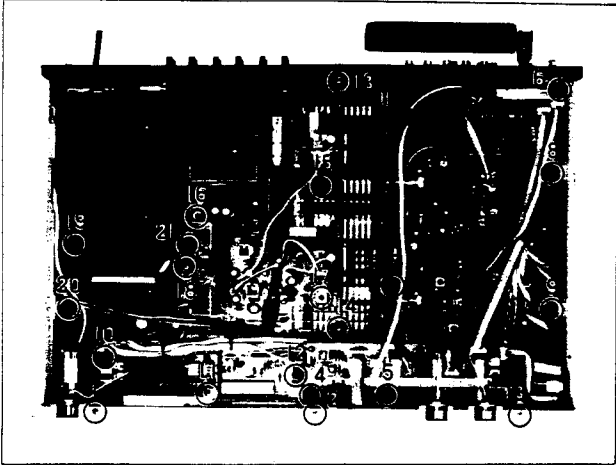

Photo 3

4. Main C. Board [2] Removal

- a. Detach the connectors and PHONO, TUNER indicator lamps which are attached to the Main C. Board.
- * Refer to Fig. 1.

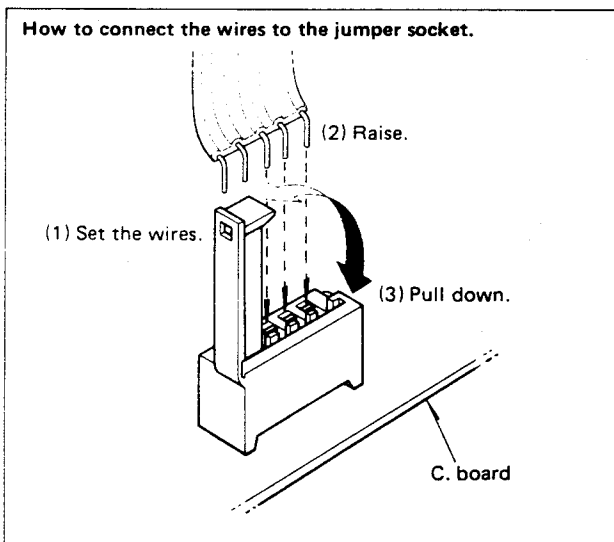

Fig. 1

- b. Remove the screws ① and ③ in photo 4 and then remove the Main C. Board [2].

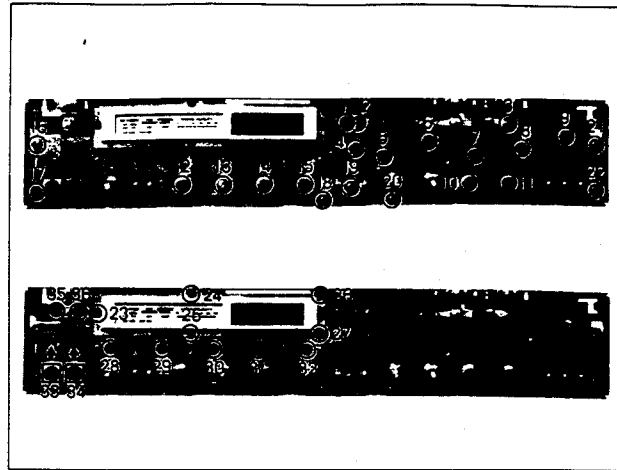

Photo 4

5. Main C. Board [4] Removal

- a. Remove the plastic rivets ④ and ⑤ in photo 4 and then remove the Main C. Board [4].
- b. Detach the lead wires which are attached to the Main C. Board [4].

6. Control C. Board [3] Removal

- a. Remove the Main C. Board. (Refer to step 4 and 5.)
- b. Remove the plastic rivets ④ to ⑧ in photo 4 and then remove the Control C. Board [3].
- c. Detach the lead wires which are attached to the Control C. Board [3].

7. Control C. Board [5] Removal

- a. Detach the lead wires which are attached to the Control C. Board [5].
- b. Remove the nut ⑨ in photo 4 and remove the Control C. Board [5].

8. Main C. Board [3] Removal

- a. Remove the connectors and Remoto Rotary Switch.
- * How to detach and attach the remoto rotary switch.

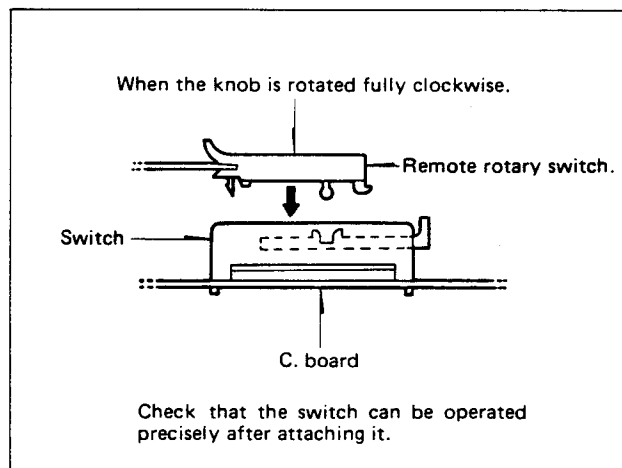

Fig. 2

- b. Detach the lead wires which are attached to the Main C. Board [3].
- c. Remove the screws ⑥ in photo 3 and ① to ④ in photo 5 and then remove the Main C. Board [3].

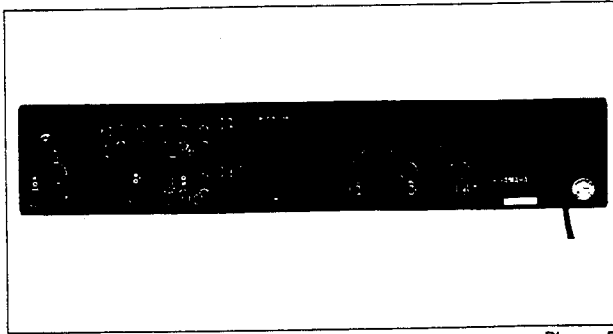

Photo 5

9. Tuner C. Board Removal

- a. Detach the connector, remote rotary switch and lead wires which are attached to the Tuner C. Board.
- b. Remove the nuts ⑩ to ⑮ in photo 4 and screws ⑯ to ⑳ in photo 4 and then remove the sub chassis unit toward yourself.
- c. Remove the screws ⑦ to ⑨ in photo 3 and the screws ⑥ to ⑪ in photo 5 and then pull out the Tuner C. Board to the front side.

10. Control C. Board [1] Removal

- a. Remove the Control C. Board [1]. (Refer to step 10.)
- b. Remove the plastic rivet ㉓ to ㉗ in photo 4 and then remove the holder unit.
- c. Remove the Control C. Board from the sub chassis unit.
- d. Detach the lead wires which are connected to the Control C. Board [1].

11. Control C. Board [3] Removal

- a. Remove the Control C. Board [1] and [4]. (Refer to step ⑩ and ⑪.)
- b. Remove the plastic rivet ㉘ to ㉚ in photo 4 and remove the Control C. Board [3].
- c. Detach the lead wires which are connected to the Control C. Board [3].

12. I AMP. C. Board Removal

- a. Detach the lead wires which are connected to the I AMP. C. Board.
- b. Remove the screws ⑬ and ⑭ in photo 3 and then remove the heat sink.
- c. Remove the screws ① to ⑦ in photo 6 and then remove the I AMP. C. Board. (L and R channel are common.)

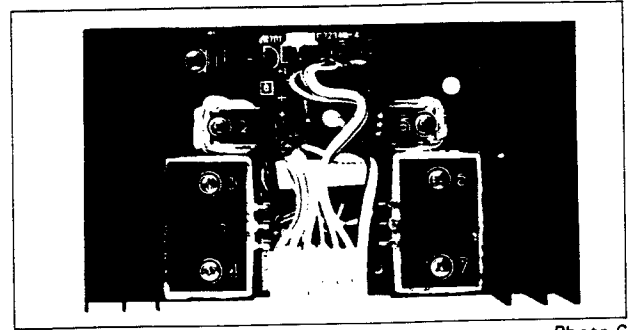

Photo 6

13. Main C. Board Removal

- a. Detach the lead wires, connectors and remote rotary switch which are connected to each C. Boards.
- b. Remove the sub chassis unit toward yourself to according to step 9 (b).
- c. Remove the heat sink according to step 12 (b).
- d. Remove the screws ⑯ to ⑲ in photo 3 and the screws ⑫ and ⑬ in photo 5 and then remove the Main C. Board gently.

14. Electrolytic Capacitor C. Board Removal

- a. Remove the screws ⑲ to ㉑ in photo 3 and then remove the Electrolytic Capacitor C. Board.
- b. Detach the lead wires which are connected to the Electrolytic Capacitor C. Board.

15. Power Transformer Removal

- a. Detach the lead wires of the Power Transformer.
- b. Remove the bottom cover according to step 2.
- c. Remove the screws ① to ④ in photo 7 and then remove the Power Transformer.

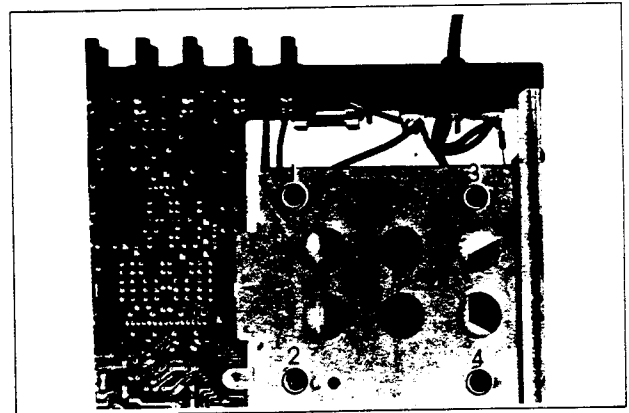

Photo 7

16. Phones Jack (Control C. Board [6]) Removal

- a. Remove the screws ㉓ and ㉔ in photo 4 and then remove the power switch.
- b. Pull out the phone jack stopper ㉗ and ㉘ to the war directed by allows in photo 4 and then remove the Control C. Board [6].
- c. Detach the lead wires which are connected to the Control C. Board [6].

MEASUREMENT AND ADJUSTMENT

1. FM TUNER ADJUSTMENT

- Before adjusting connect the auxiliary center meter (Ji00036 or similar one) between S and NVCC.
- Set the switches to the following positions.
 Band select. FM
 RX MODE AUTO
 TUNING LEVEL HIGH
 MUTING ON
- During adjustments, use a low-pass filter.
- Start adjustment, after waiting 5 minutes following power switch-on.

- Do not forget to keep the bottom cover on.
- Abbreviation of Instruments
 FM S.G. : FM Signal generator
 DM : Digital multimeter
 OSC. : Oscilloscope
 DIST.M. : Distortion meter
 F.C. : Frequency counter
 ST SG : Stereo Signal generator

ADJUSTING POINTS

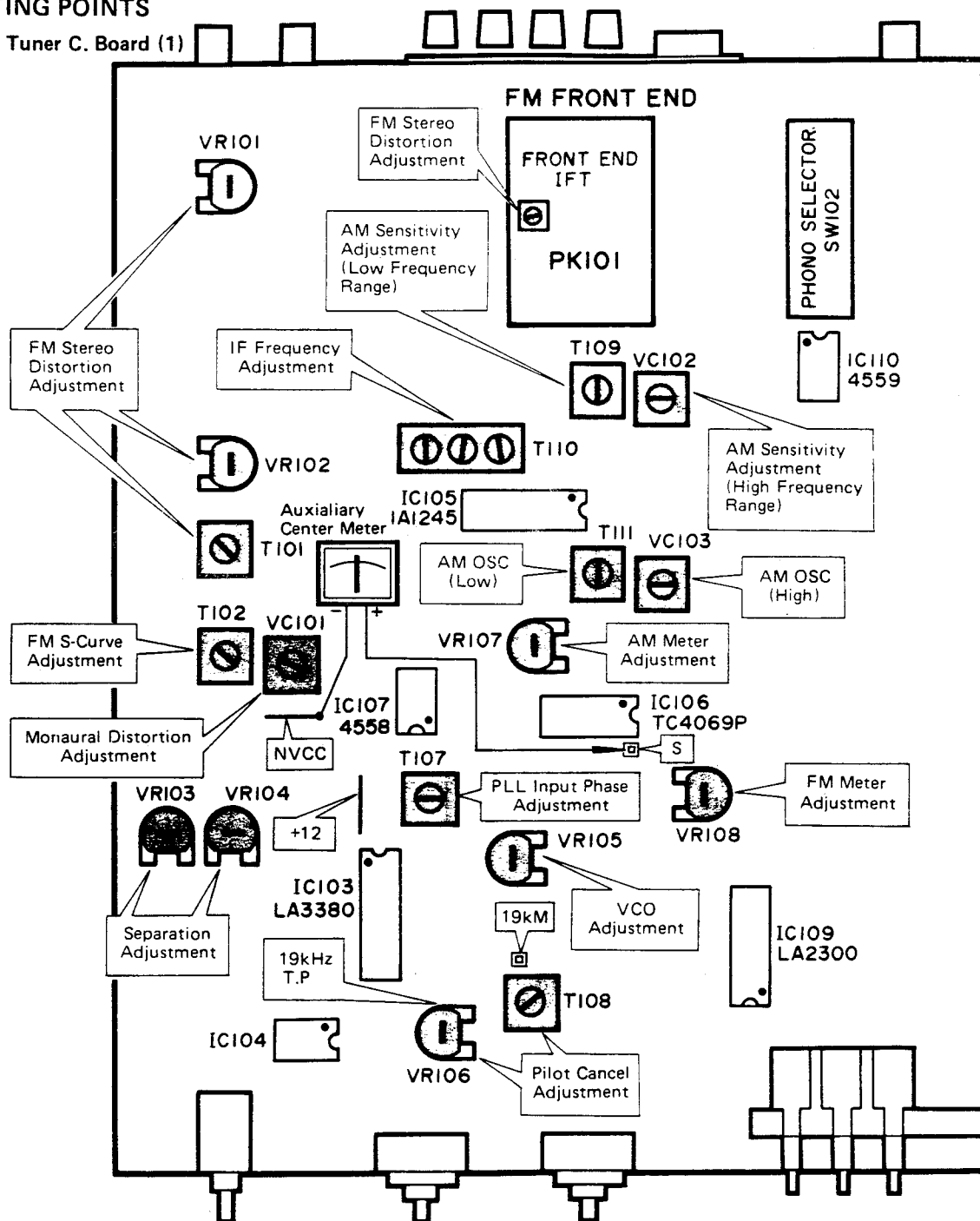

Fig. 3

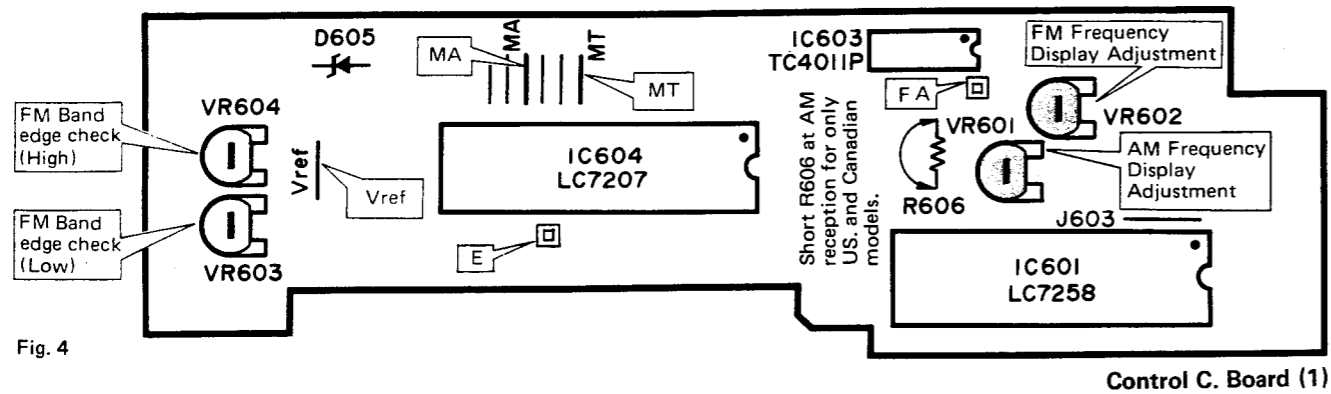

Fig. 4

Step	Adjustment item	Terminals to be connected	Instrument required	Adjustment location	Adjustment method	Rating or standard	Remarks
1	External VR setting	MT, Vref, E (control c. board)	Connect VR between Vref and E. Connect the center tap of VR to MT. (Refer to Fig. 5)				Tune manually with this VR when adjusting.
2	Manual set	MA E	Short wire		Short MA (TP) and E for a moment. (Refer to Fig. 5)		Set MA to L level once.
3	S curve adjustment	FM antenna terminal (300Ω balanced ANT) S, E terminal	OSC DM FM SG/ST SG DIST. M	T102 (discriminator coil)	At detuned point MUTE DX LOCAL ON 4.5 ~ 5.0V OFF 4.0 ~ 5.5V		
4	Tuning point setting	FM antenna terminal	FM SG 98MHz Antenna input: 70dBμ	External VR	Adjust VR so that the voltage between S and E is 4.5 ~ 5.0V		Check that JF MODE switch becomes Local.
5	Monaural distortion adjustment	FM antenna terminal output	FM SG 98MHz Antenna input: 70dBμ Monaural: 1kHz 100% modulation OSC DM DIST. M	VC101 (trimmer)	Reduce distortion to minimum.	Less than -60dB (-70dB)	Check that JF MODE Switch becomes Local.
6	VCO adjustment	FM antenna terminal output 19KM, ME	FM SG 98MHz non-modulation F.C. 1MΩ resistor	VR105	Set to 19kHz when forcing the set into the stereo mode. (Refer to Fig. 6)	19kHz ± 20Hz (± 10Hz)	Check that JF MODE Switch becomes Local.
7	PLL input phase adjustment	Same as step 6	FM SG 98MHz Antenna input: 70dBμ Stereo L,R: 1kHz 100% modulation DM	T107	Adjust so that L and R output are at maximum.		Check that JF MODE Switch becomes Local.
8	Stereo distortion adjustment	Same as step 6	FM SG 84MHz Antenna input: 70dBμ Stereo L,R: 1kHz 100% modulation OSC DM DIS. M	T101 VR101 VR102 Front end IFT	Reduce distortion to minimum	Less than -60dB (-70dB)	Check that JF MODE Switch becomes Local.
9	Separation adjustment	Same as step 6	Same as step 8	VR103 (L → R) VR104 (R → L)	Adjust so that separation is at maximum.	More than 40dB (58dB)	Check that JF MODE Switch becomes Local.
10	Pilot canceling adjustment	Same as step 6	Same as step 8 Pilot: 9% modulation	T108 VR106	Observe wave forms on oscilloscope and adjust so that leak level is reduced to minimum.	Less than -50dB (-60dB)	Check that JF MODE Switch becomes Local.
11	Signal meter full scale adjustment	Same as step 6	Same as step 8 Stereo L,R: 1kHz 100% modulation	VR108	Adjust so that LED of signal meter is at full scale.		Check that LED is not out at detuned point.
12	S curve offset check	Same as step 3			Adjust over again from step 3 when S curve offset is not found to be within specified value. Check that IF MODE Switch becomes AUTO.		

Step	Adjustment item	Terminals to be connected	Instrument required	Adjustment location	Adjustment method	Rating or standard	Remarks
13	Frequency display adjustment (IF offset)	Same as step 4	FM SG 98MHz Antenna input: 70dBμ Stereo (frequency accuracy: within ± 5kHz)	VR602	Tune so that the voltage between S and E becomes 4.5V ~ 5V. Four figure display: The best point is found when the number of tenth figure changes. Five figure display: Connect 22kΩ between FA and E. The best point is found when the on and off of the display of 100k figure is stopped. North European, British models. (Refer to Fig. 5)		
14	Band edge check (receiving frequency range check)	Same as step 4	Same as step 13 * Connect J603 to control c. board and detach after adjustment except North European and British models.	VR603 VR604	Set to the highest frequency with external VR. Adjust VR604 so that display frequency becomes 108.35MHz. Next, memorize in CH1 and read. Adjust with VR603 so that display becomes 87.35MHz.		
15	Auto reception check	Same as step 4	FM SG 98MHz Antenna input: 70dBμ		Press UP and DOWN switch. Receive 87.5MHz and 108MHz station.		
16	Tuning level check	Same as step 4	FM SG 98MHz Antenna input: 20dBμ		Check that Tuning LEVEL switch is not stopped at HIGH when the set is auto tuned.		

* Specified values are ones that are able to be measured with YHP4333A (except step 1, 7 and 14).

* Step 1 shows the circuit for easy adjustment that holds an optional frequency.

* Step 2 means the rest operation to operate manually.

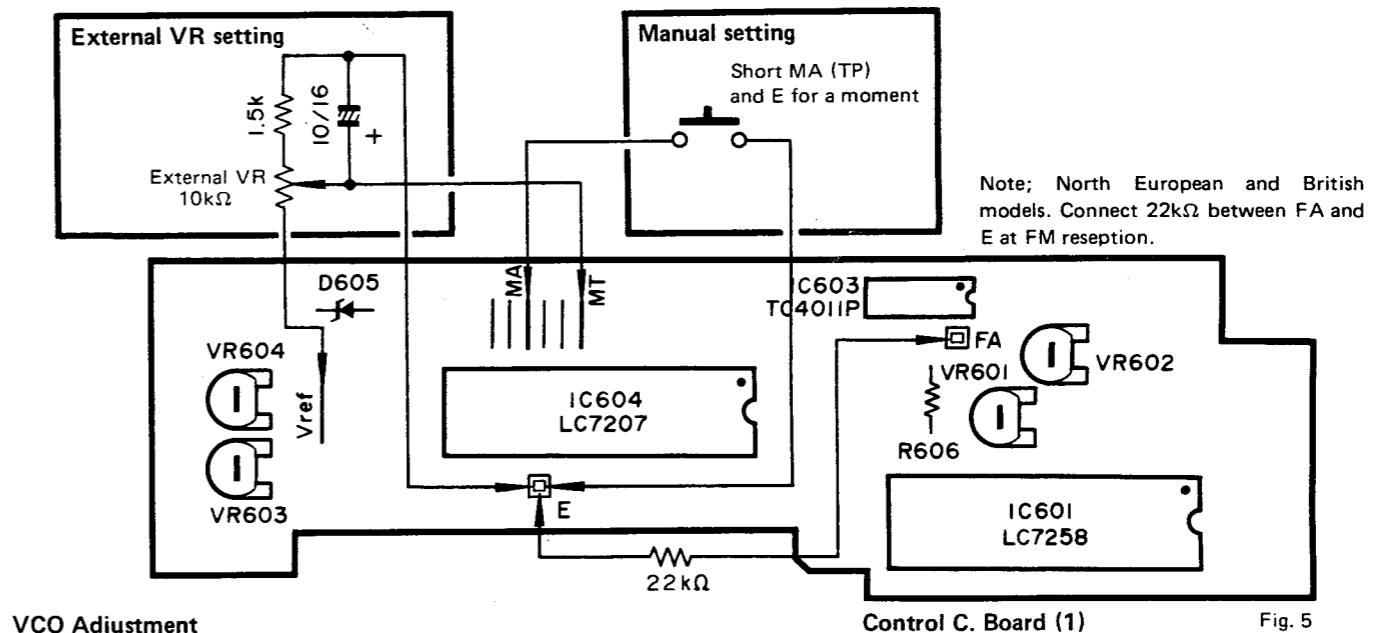

Fig. 5

VCO Adjustment

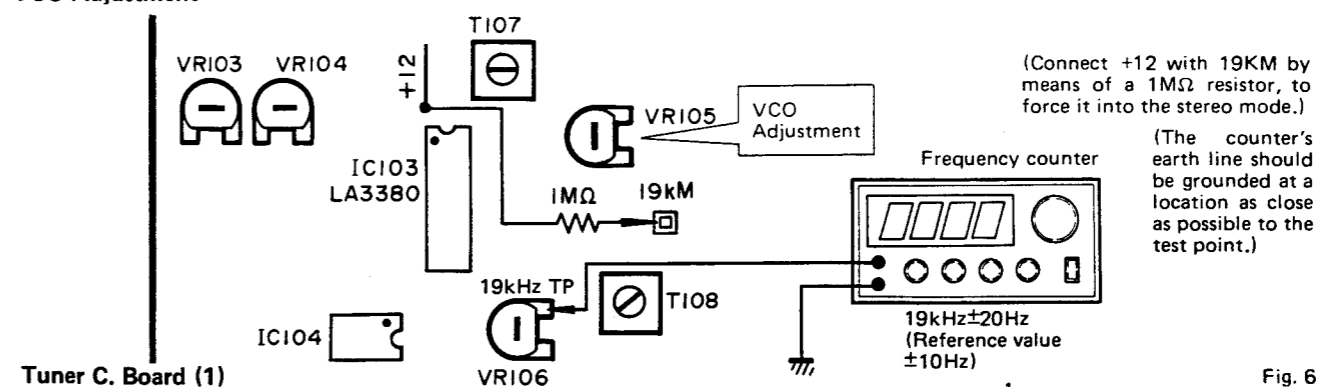

Fig. 6

Tuner C. Board (1)

2. AM TUNER ADJUSTMENT

- This is to be carried out after adjustment of the FM tuner section has been completed.
- As a rule, the local oscillator coil is not to be turned.
- Connect the AM loop antenna to the AM ANT terminals.

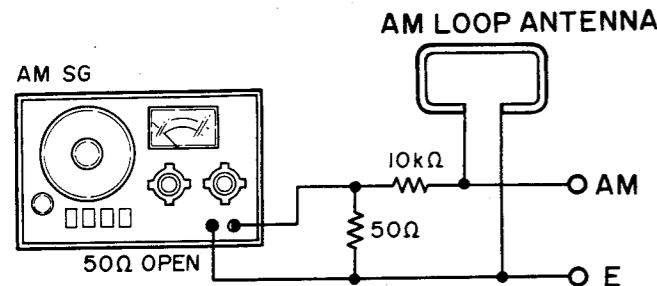
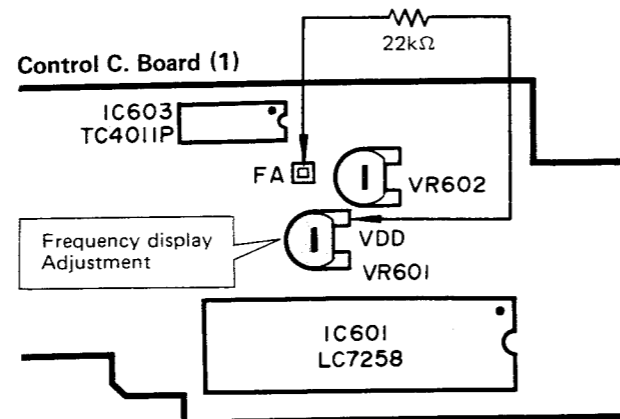

Fig. 7

- Set BAND SELECTOR to AM.
- Abbreviation of instruments
AM S.G. . . . AM signal generator



Connect 22kΩ between FA and VDD (21 pin of IC601) at AM reception.

Fig. 8

Step	Adjustment item	Terminals to be connected	Instrument required	Adjustment location	Adjustment method	Rating or standard	Remarks
1	External VR setting MANUAL setting				Perform Steps 1 & 2 of FM section adjustment		
2	S-curve center check	S-E terminal	OSG DM		At detuned point	4.2V ± 1V	
3	IF frequency adjustment	Connect dummy antenna to ANT terminal output L or R	AM SG 450.00kHz 100dBμ ~ 120dBμ	T110	Adjust so that the detector output is at maximum.		Refer to Fig. 7
4	Lowest receiving frequency adjustment	Same as step 3		T111	Preset to CH1 and read. Display 515kHz	± 1kHz	
5	Highest receiving frequency adjustment	Same as step 3		VC103	Set manually. Set the manual VR at maximum. Display 1620kHz	± 1kHz	
6	Low frequency range sensitivity adjustment	Same as step 3	600kHz 40 ~ 50dBμ	T109	Set the sensitivity at maximum		
7	High frequency range sensitivity adjustment	Same as step 3	1450kHz 40 ~ 50dBμ	VC102	Same as step 6		
8	Tuning range sensitivity difference	Same as step 3	Repeat from step 4 to 7		Same as step 6		
9	Signal meter full scale adjustment	Same as step 3	950kHz 80dBμ	VR107	Set the signal meter to full scale (LED indicator lights up.)	LED indicator puts out at detuned point.	
10	Frequency display adjustment	Same as step 3	950.00kHz	VR601	Tune so that the voltage between S and E is 4.5 ~ 5.0V. Connect 22kΩ between FA and VDD (21 PIN of IC601). Adjust so that the on and off of 1kHz figure stops. (Refer to Fig. 8)		For U.S. & Canadian models, short R606 (2.2MΩ) on the control circuit board and set to 1kHz display and then adjust.
11	Auto reception check	Same as step 3	950.00kHz		Press UP and DOWN switch. Receive 525kHz and 1605kHz station.		

* Use the dummy antenna shown in Fig. 4. (Do not connect the loop antenna.)

3. Audio section adjustment

- After the power switch is ON. Wait 5 minutes before measuring to be sure of the most stable operation.
- Connect dummy load (8Ω) to the speaker terminals.

a. DC offset voltage adjustment

- Test point : TP 1 – Earth (L and R channels)
- Adjustment volume : VR406 (Main amp. P.C.B)
- Adjustments
Observe L and R channels on the digital multimeter at the same time and adjust VR. Set to the point that DC offsets of Both channels are at minimum.
Less than 0 ± 100mV

* When adjusting VR406, DC offsets of both channels changes, so set to the point that the balance of L and R channels is best.

b. Idling current adjustment

- Test point : TP1 – TP2 (I amp. P.C.B. L and R channels)
- Adjustment volume : VR701 (I amp. P.C.B. L and R channels)
- Adjustment
Adjustment VR701 and then set the voltage between TP1 and TP2 to 6 ± 3mV on digital multimeter.

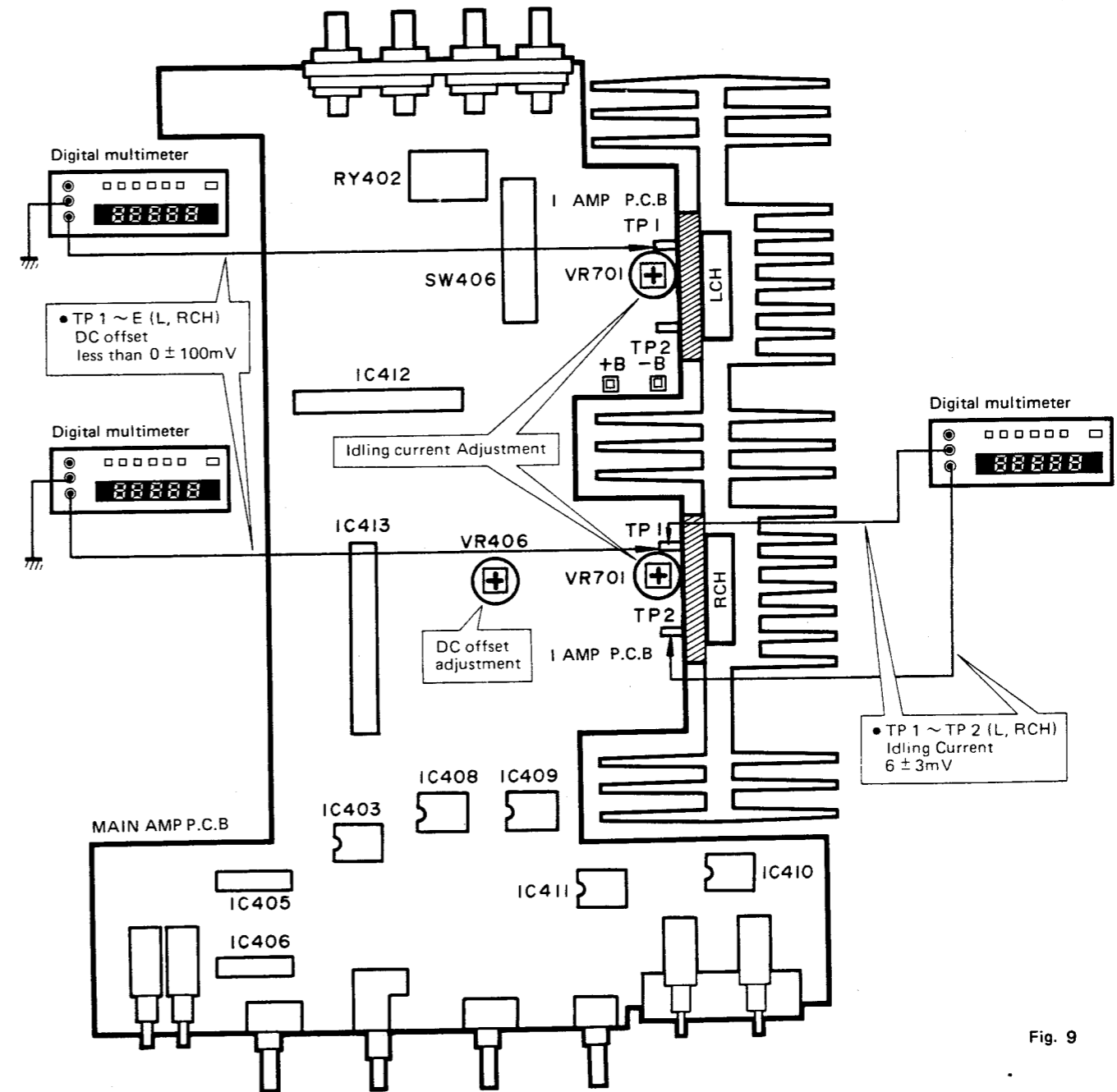

Fig. 9

SPECIFICATION

● AUDIO SECTION	
Minimum RMS Output Power per Channel	
8Ω, 20 to 20,000Hz, 0.015% THD	150W (21.8dBW)
8Ω, 1kHz, 0.01% THD	165W (22.2dBW)
8Ω, 20 to 20,000Hz, 0.005% THD, Main In	150W (21.8dBW)
Dynamic Headroom (8Ω)	3dB
Total Harmonic Distortion (20 to 20,000Hz)	
Phono MM to Rec Out (3V output)	0.005%
Phono MC to Rec Out (3V output)	0.01%
Aux/Tape to Pre Out (2V output)	0.005%
Aux/Tape to Sp Out (8Ω, 1W)	0.005%
Main In to Sp Out (8Ω, 1W)	0.005%
IM Distortion Ratio	
Aux/Tape to Sp Out (8Ω, 75W)	0.01%
Power Bandwidth (8Ω, 75W 0.02% THD)	5 to 40,000Hz
Damping Factor (8Ω, 1kHz)	Better than 60
Frequency Response	
(Aux/Tape to Sp Out, 8Ω)	5 to 50,000Hz, -1dB
(Main In, DC to 100,000Hz)	-1dB
RIAA Deviation	
Phono MM (20 to 20,000Hz)	± 0.2dB
Phono MC (30 to 20,000Hz)	± 0.3dB
Input Sensitivity/Impedance	
Phono MM	2.5mV/47kΩ, 100pF or 220pF
	2.5mV/100kΩ, 100 pF
Phono MC	100μV/100Ω
Aux/Tape	120mV/47kΩ
Main In	1V/47kΩ
Input Sensitivity (New IHF)	
Phono MM	0.2mV
Phono MC	8.2μV
Aux/Tape	9.8mV
Maximum Input Level (0.01% THD)	
Phono MM (20 to 20,000Hz)	250mV
Phono MM (1kHz)	280mV
Phono MC (1kHz)	11mV
Output Level/Impedance	
Rec Out (Phono)	120mV/470Ω
Pre Out	1V/430Ω
Headphone Output	780mW (0.015% THD)
Signal-to-Noise Ratio (IHF A Network)	
Phono MM (5mV, Input Shorted)	90dB
Phono MC (500μV, Input Shorted)	84dB
Aux/Tape (Input Shorted)	100dB
Main In (Input Shorted)	120dB
Signal-to-Noise Ratio (New IHF)	
Phono MM	80dB
Phono MC	77dB
Aux/Tape	87dB
Main In	100dB
Residual Noise (IHF A Network)	50μV
Channel Separation (1kHz, vol -30dB, 5.1kΩ)	
Aux/Tape to Other Channel	-64dB
Phono MM to Other Channel	-64dB
Tone Control Characteristics	
Bass (boost/cut)	± 11dB at 80Hz
Treble (boost/cut)	± 12dB at 10kHz
Center Frequencies	
Bass	80Hz
Treble	10kHz
Presence Control Range	± 8dB (Center Frequency)
Center Frequency	0.8/1.6/3.2kHz
Filter Characteristics	
Low (Subsonic)	15Hz, -12dB/oct
High	8kHz, -6dB/oct
Continuous Loudness Control (Level-Related Equalization)	
Max. Attenuation	-20dB at 1kHz
Rec. Output Level/Impedance (Fixed)	
FM (100% mod. 1kHz)	500mV/1.8kΩ
AM (30% mod. 1kHz)	150mV/1.8kΩ

● FM SECTION	
Tuning Range	87.6 to 108MHz
50dB Quieting Sensitivity	
Mono (DX)	2.8μV (14.2dBf)
Stereo (DX, Auto Blend)	25μV (33.2dBf)
Usable Sensitivity	
IHF Mono (1kHz 100% mod.) (300Ω)	2.0μV (11.3dBf)
(75Ω)	1.0μV (11.3dBf)
(1kHz, 30% mod.)	
300Ω	1.6μV (9.3dBf)
75Ω	0.8μV (9.3dBf)
Image Response Ratio (98MHz)	70dB
IF Response Ratio (98MHz)	100dB
Spurious Response Ratio (98MHz)	100dB
AM Suppression Ratio (IHF)	65dB
Capture Ratio (IHF)	Local 1.2dB, DX 2.5dB
Alternate Channel Selectivity (IHF)	Local 30dB, DX 82dB
Selectivity (Two Signals)	DX 68dB
Signal-to-Noise Ratio, Mono	85dB
Stereo	81dB
Distortion	
Mono 100Hz	Local 0.06%, DX 0.1%
1kHz	Local 0.06%, DX 0.5%
6kHz	Local 0.08%, DX 0.7%
Stereo 100Hz	Local 0.07%, DX 0.1%
1kHz	Local 0.07%, DX 0.5%
6kHz	Local 0.09%, DX 0.8%
Intermodulation Distortion (IHF)	
Mono	Local 0.07%, DX 0.5%
Stereo	Local 0.08%, DX 1.0
Stereo Separation (Local)	
50Hz	50dB
1kHz	50dB
10kHz	45dB
Frequency Response	
50Hz to 10kHz	± 0.3dB
30Hz to 15kHz	+ 0.3/ -0.5dB
Subcarrier Product Ratio	65dB
Muting Threshold (DX)	2.8μV (14.2dBf)
Auto-DX Threshold	32μV (35.3dBf)
Tuning Level Threshold	56μV (40.2dBf)

● AM SECTION	
Tuning Range	525 to 1,605kHz
Usable Sensitivity (Loop Antenna)	200μV (46dBμ/m)
Selectivity	30dB
Signal-to-Noise Ratio	50dB
Image Response Ratio	40dB
Spurious Response Ratio	50dB
Distortion (1kHz)	0.3%
Tuning Level Threshold	3mV (70dBμ/m)

● GENERAL	
Semiconductors	
U.S., Canada and General	75 Transistors, 33ICs, 7FETs, 70 Diodes, 22 LEDs
Northern Europe, British and Australia	78 Transistors, 33ICs, 7FETs, 77 Diodes, 22 LEDs
Power Supply	
U.S. and Canada	120V, 60Hz
General	110-120V/220-240V, 50/60Hz
Northern Europe	220V, 50Hz
Britain and Australia	240V, 50Hz
Power Consumption	
U.S. and Canada	550W
Northern Europe, Britain and Australia	920W
General	330W
Dimensions (W x H x D)	540 x 122 x 385.6 mm (21-1/4" x 4-3/4" x 15-1/4")
Weight	
U.S. and Canada	13.3kg (29lbs. 5oz.)
Northern Europe	13kg (28lbs. 10oz.)
British, Australia and General	13.1kg (28lbs. 14oz.)

Specifications subject to change without notice.

BLOCK DIAGRAM

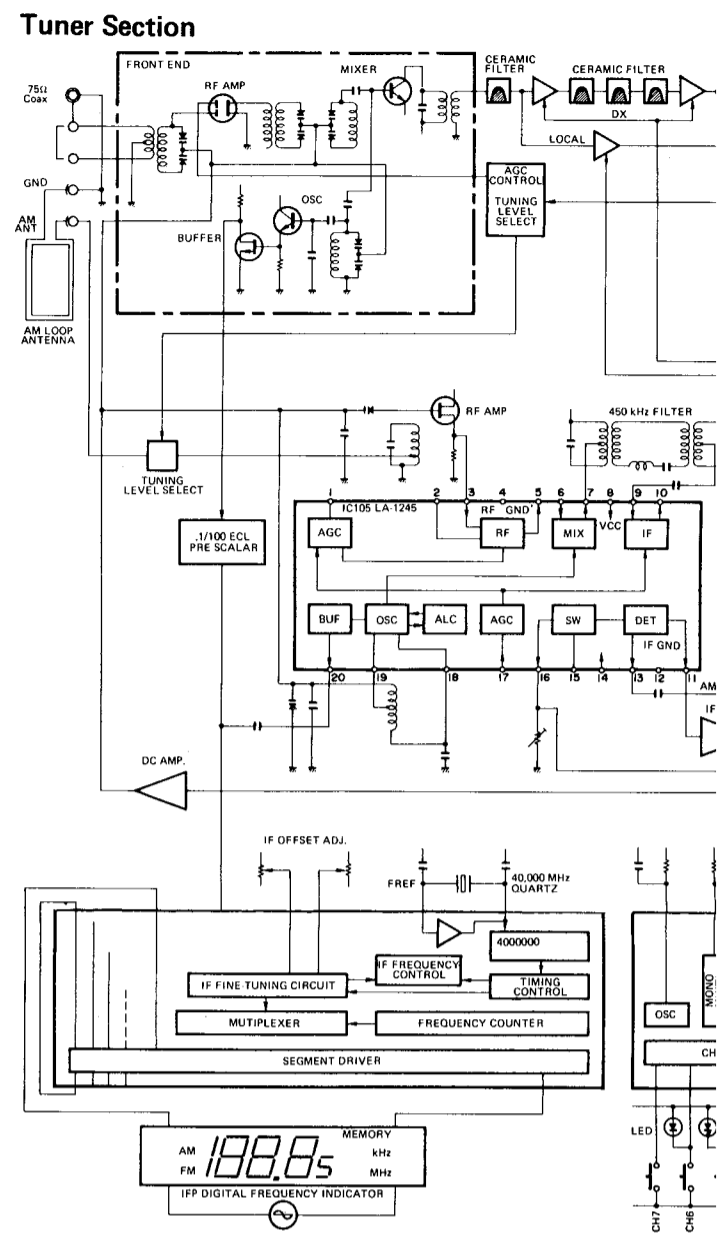

Audio Section

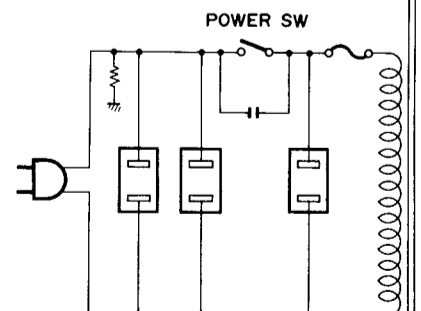
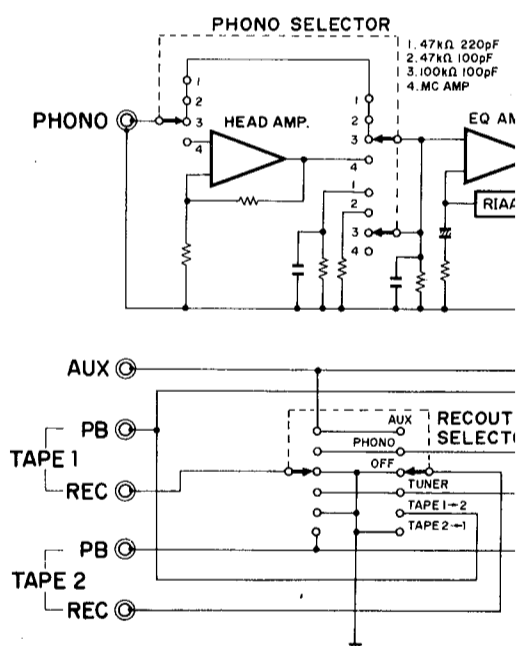

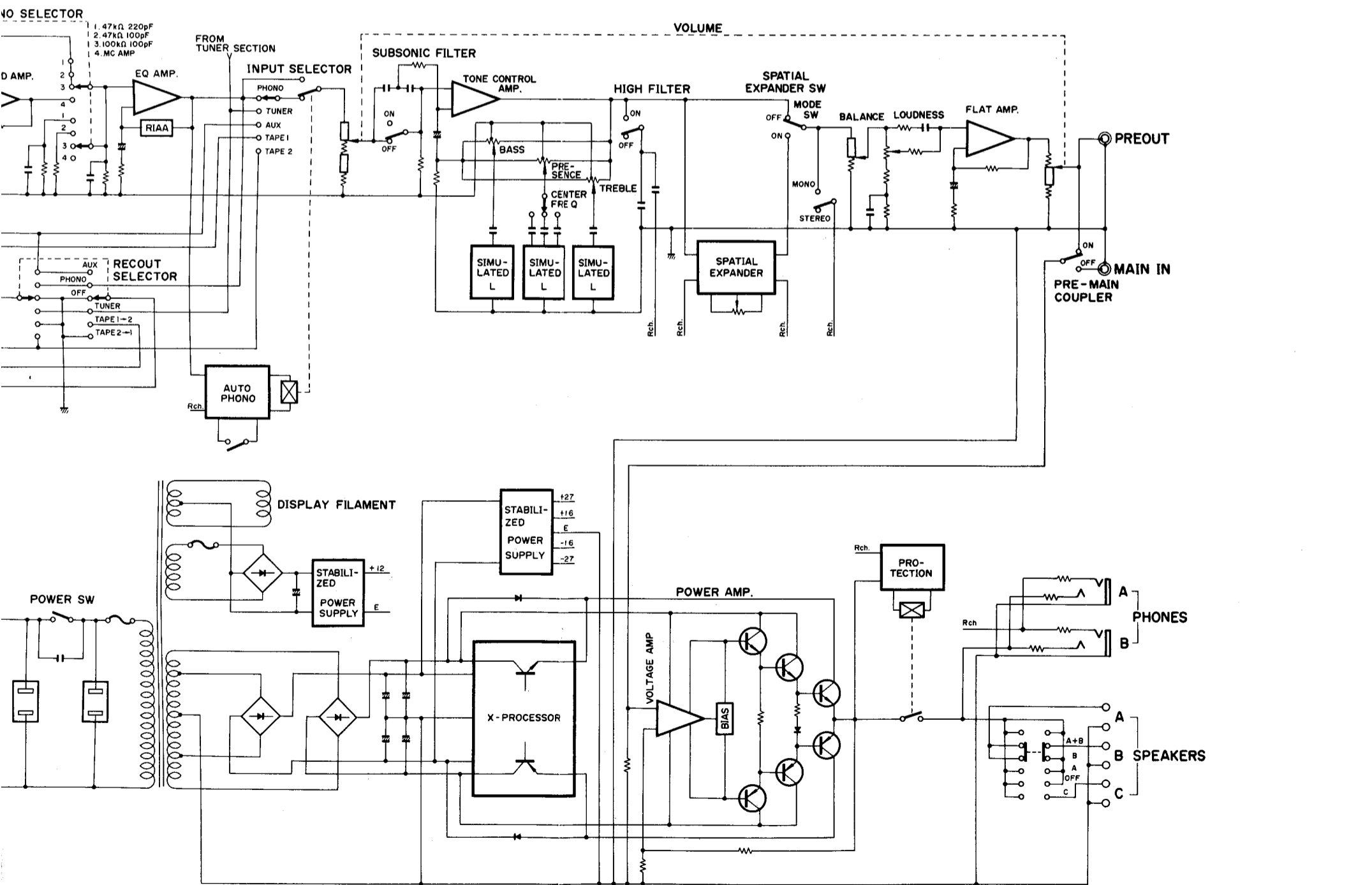
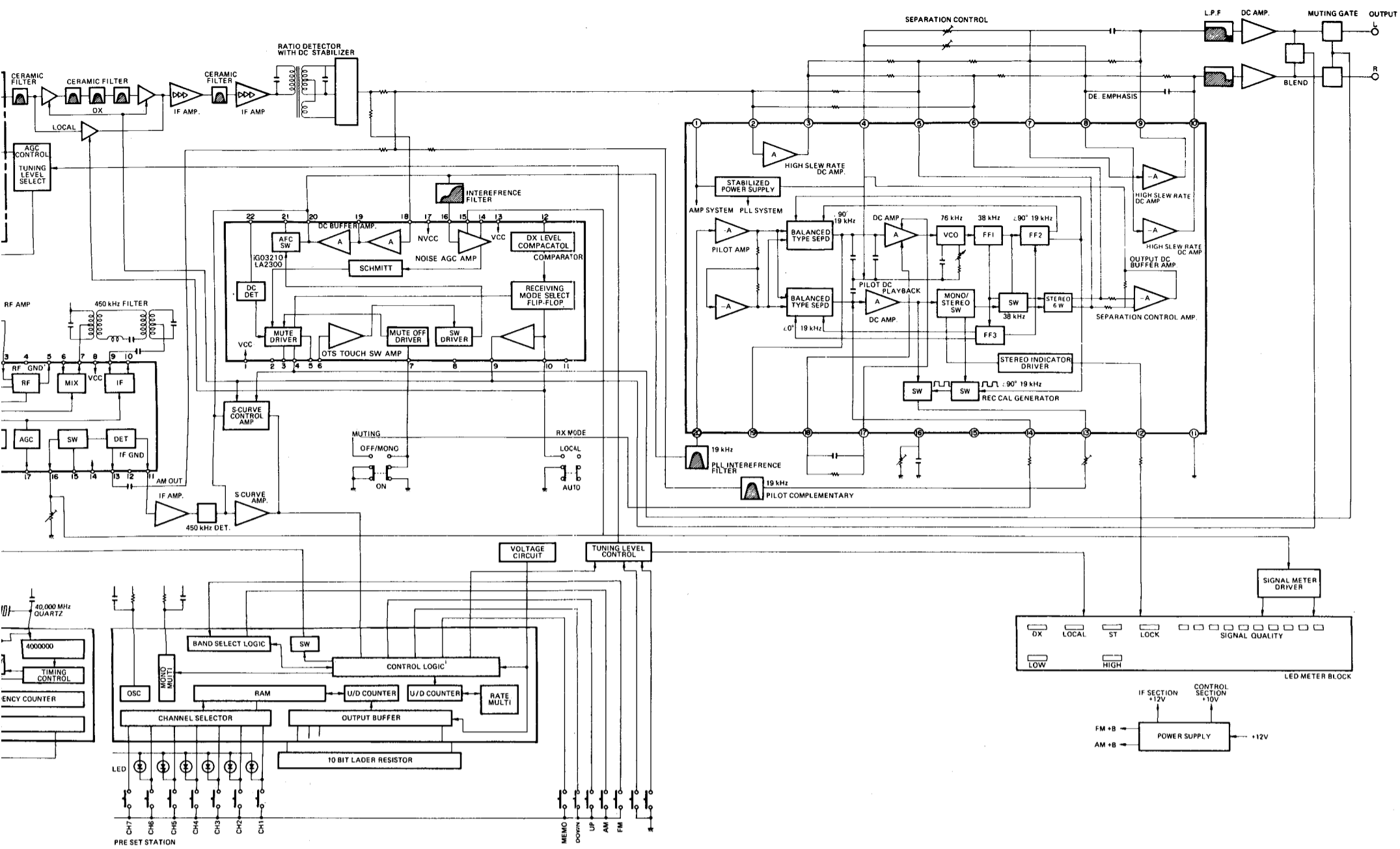

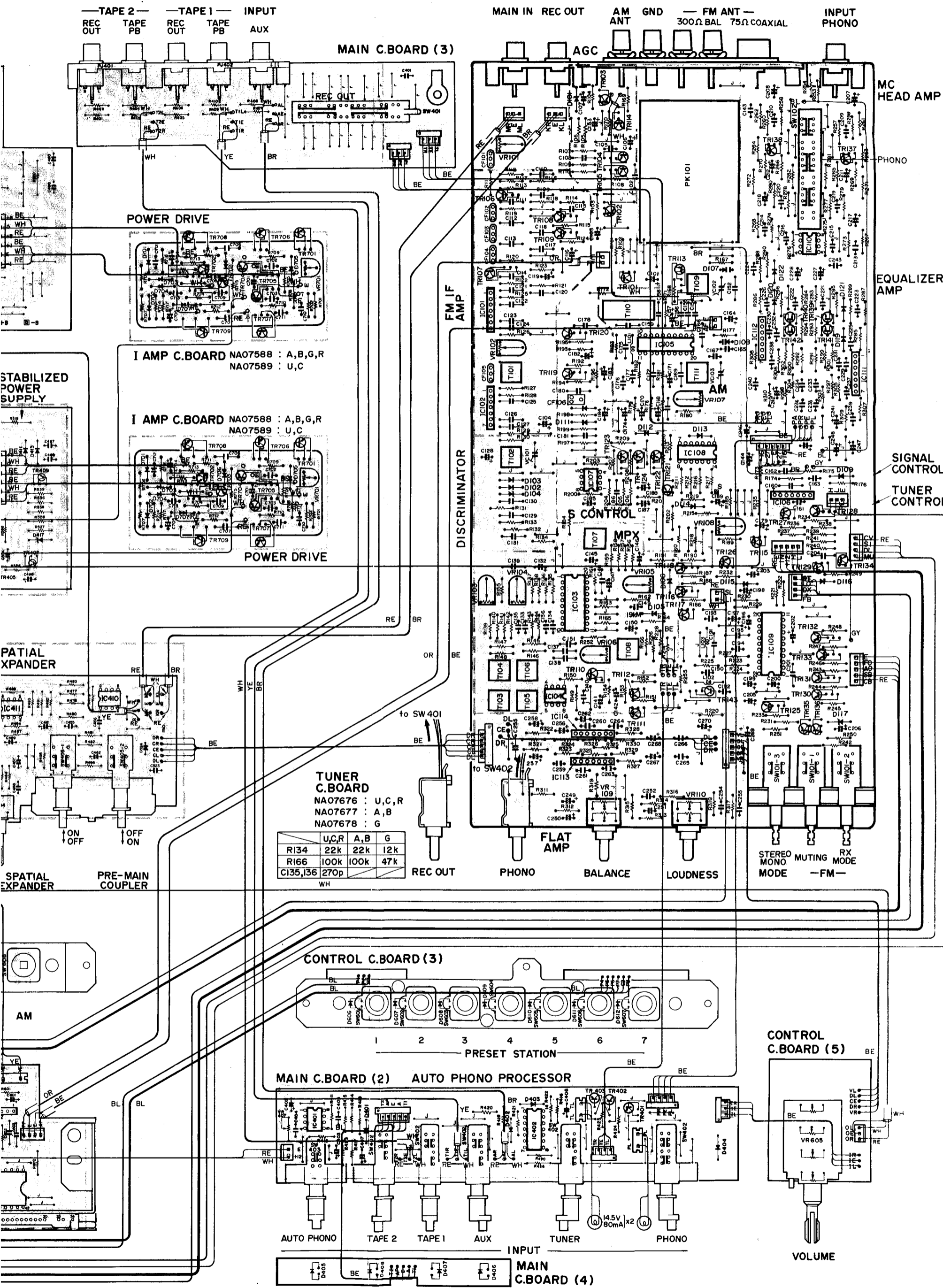

MAIN C.B.O.A.R.D (3)

POWER DRIVE

I AMP C.B.O.A.R.D NA07588 : A,B,G,R
NA07589 : U,C

I AMP C.B.O.A.R.D NA07588 : A,B,G,R
NA07589 : U,C

POWER DRIVE

TUNER C.B.O.A.R.D
NA07676 : U,C,R
NA07677 : A,B
NA07678 : G

	U,C,R	A,B	G
R134	22k	22k	12k
R166	100k	100k	47k
C135,136	270p		

CONTROL C.B.O.A.R.D (3)

MAIN C.B.O.A.R.D (2) AUTO PHONO PROCESSOR

CONTROL C.B.O.A.R.D (5)

MAIN IN REC OUT AM ANT GND FM ANT 300Ω BAL 75Ω COAXIAL INPUT PHONO

MC HEAD AMP

PHONO

EQUALIZER AMP

SIGNAL CONTROL

TUNER CONTROL

REC OUT PHONO BALANCE LOUDNESS

STEREO MONO MUTING MODE RX MODE -FM-

1 2 3 4 5 6 7
PRESET STATION

AUTO PHONO TAPE 2 TAPE 1 AUX INPUT TUNER PHONO

VOLUME

MAIN C.B.O.A.R.D (4)

WIRING DIAGRAM

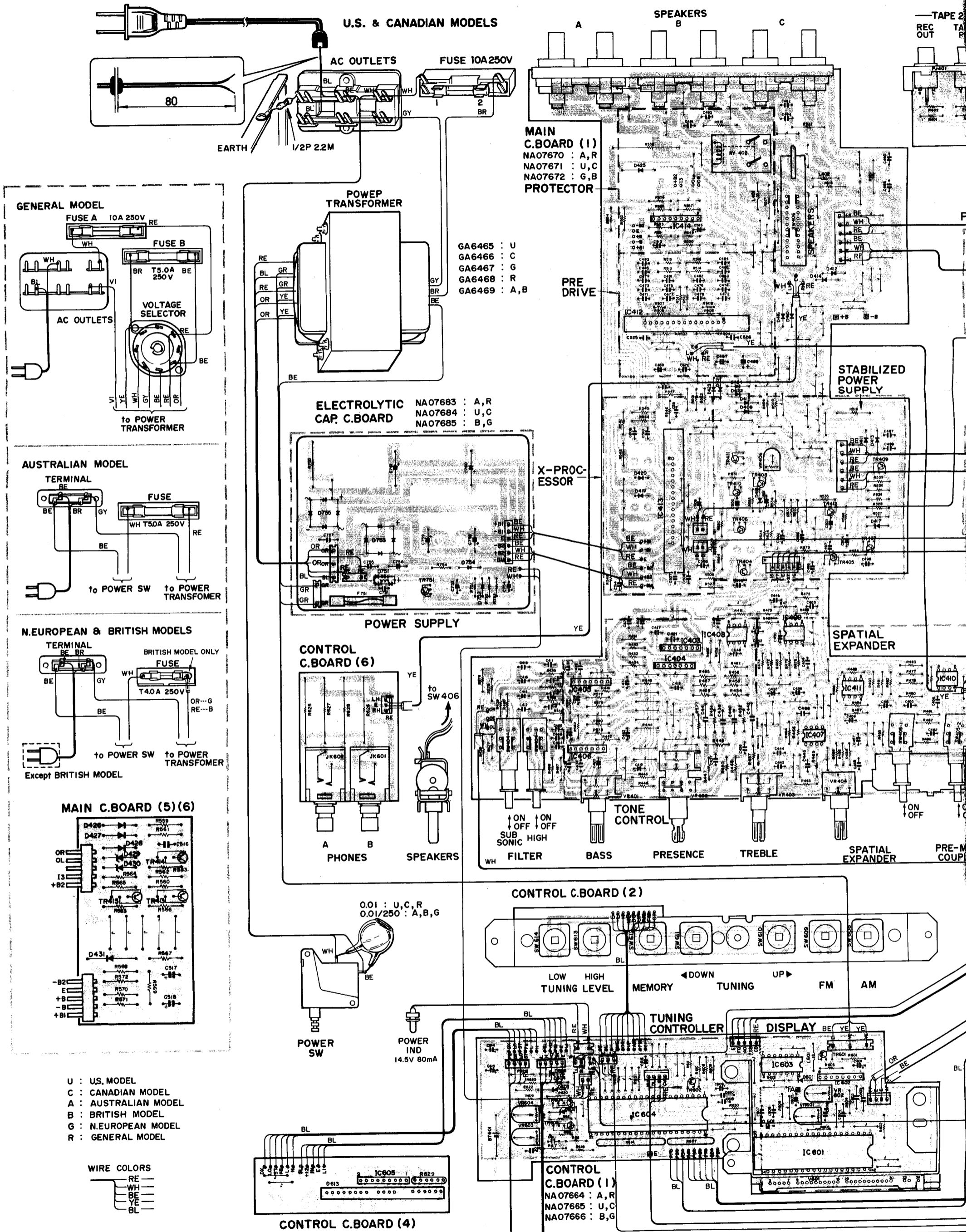

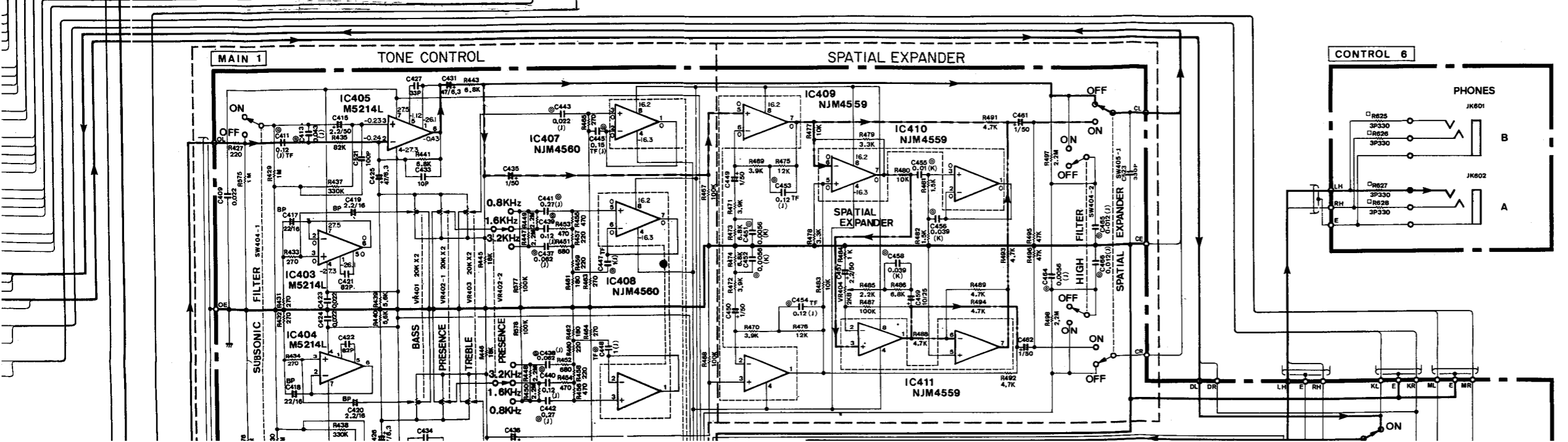
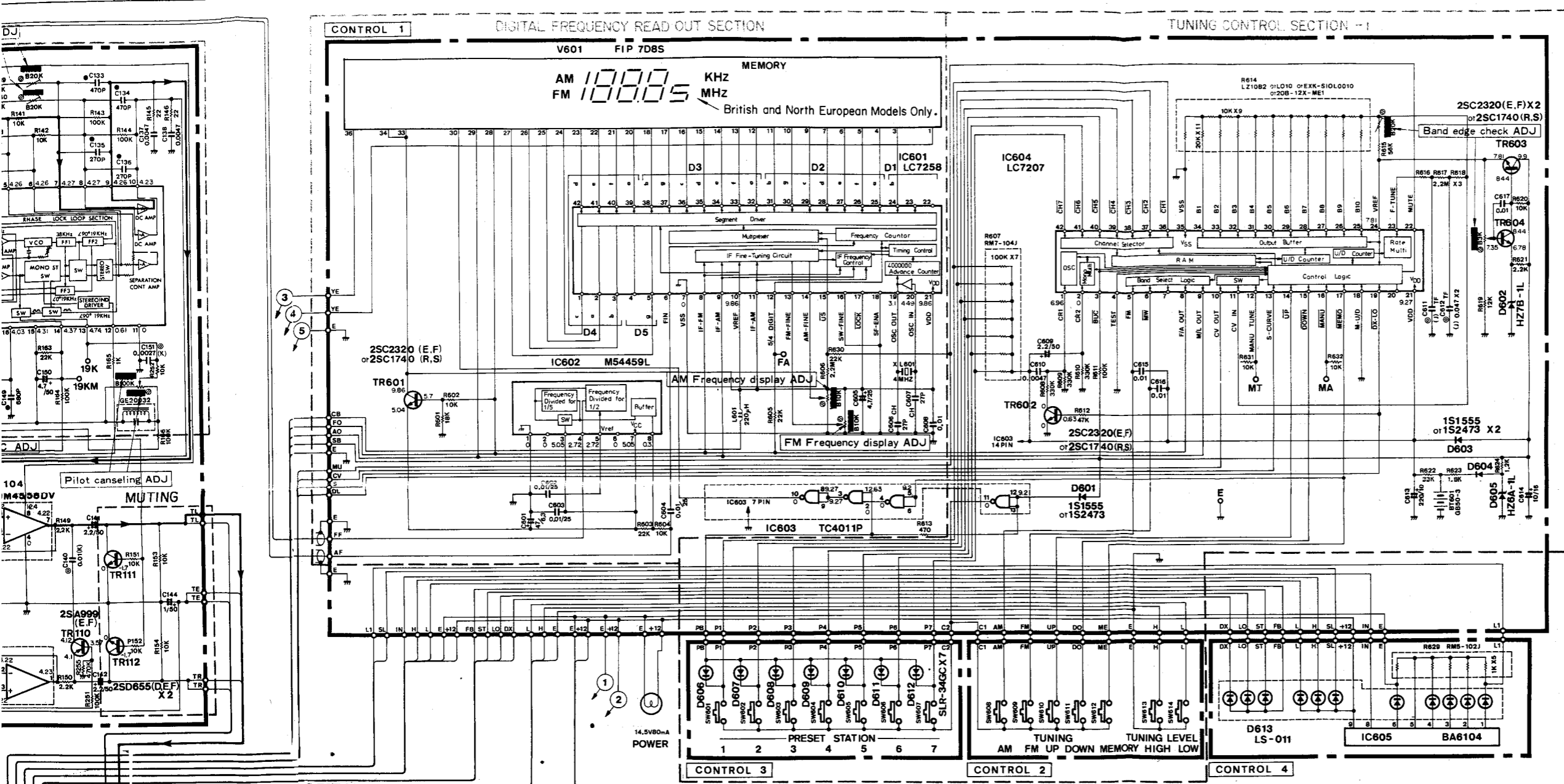

PIN-CONNECTION DIAGRAM OF TRANSISTORS, DIODES AND ICs.

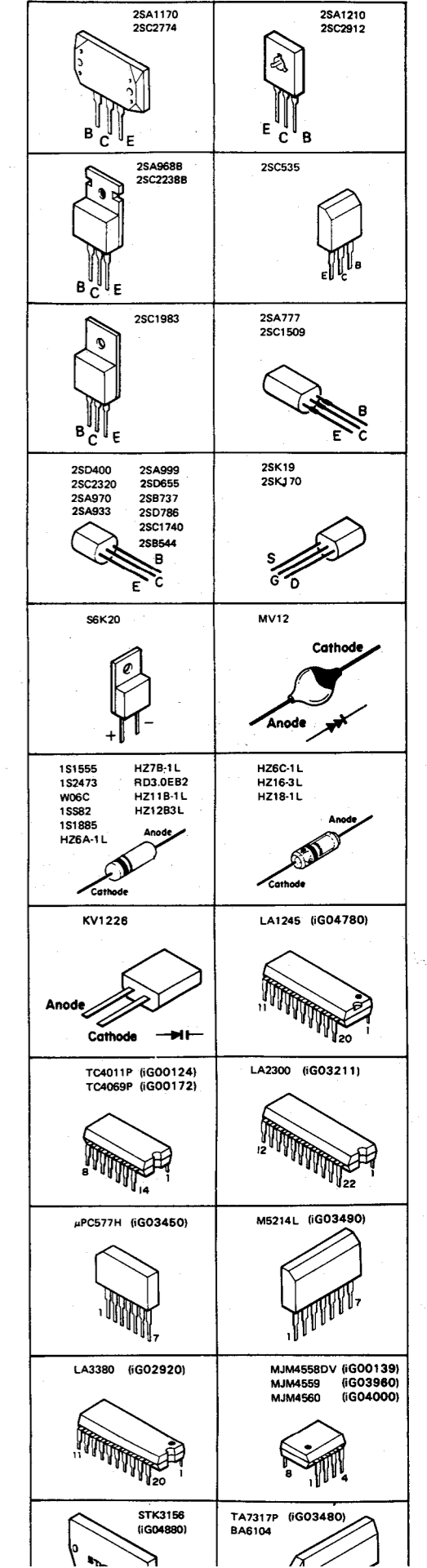

SCHEMATIC DIAGRAM

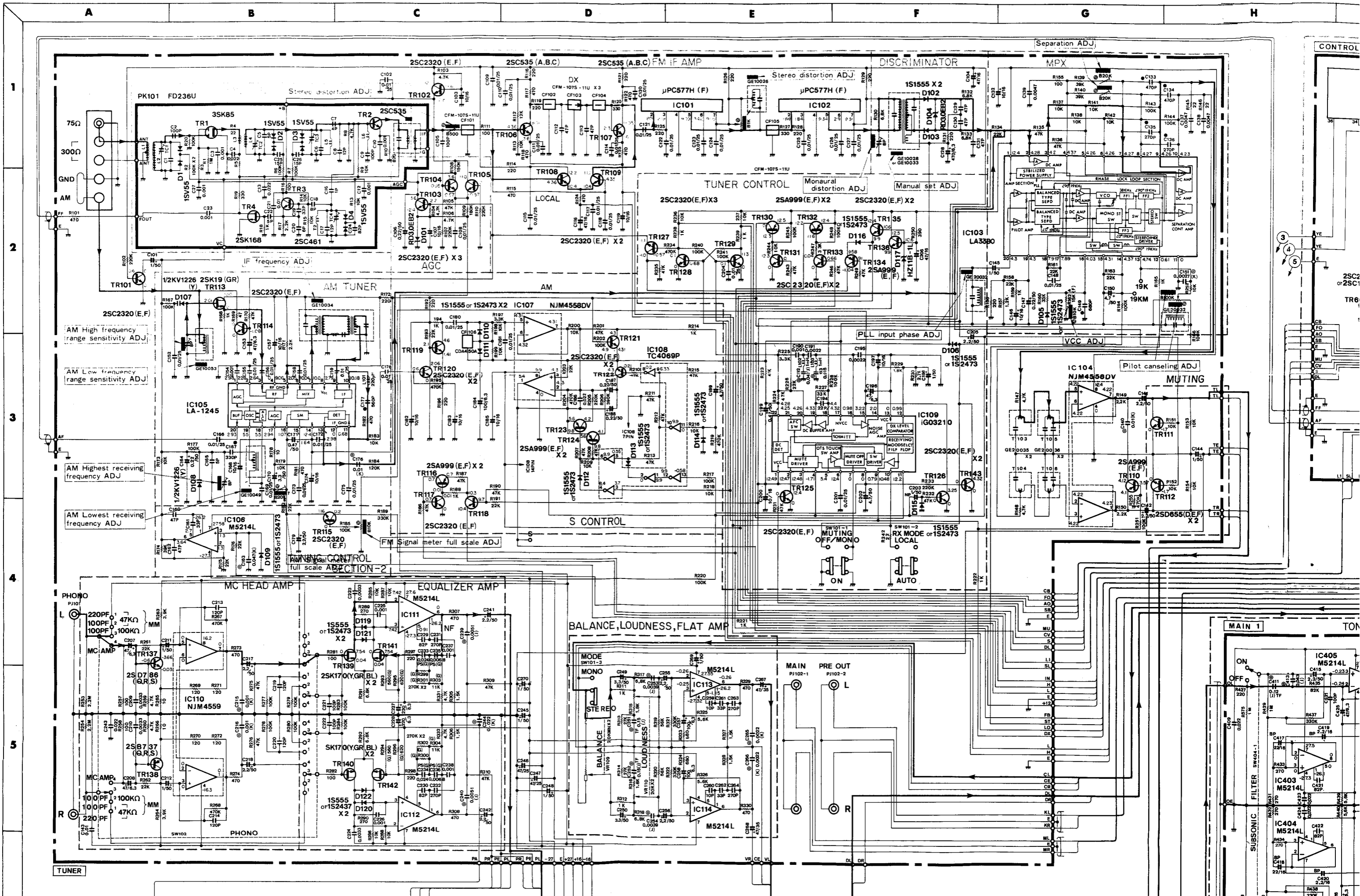

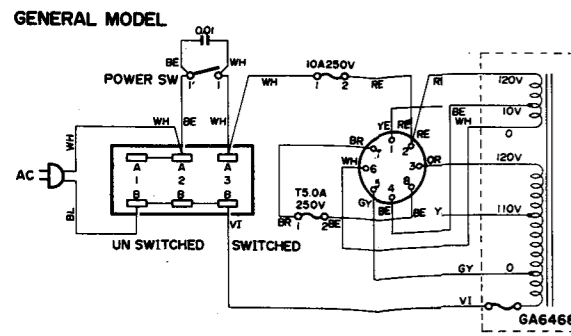
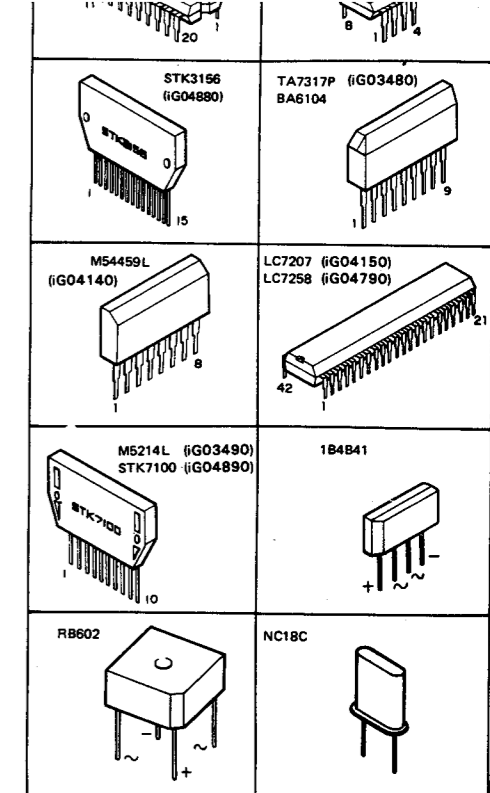
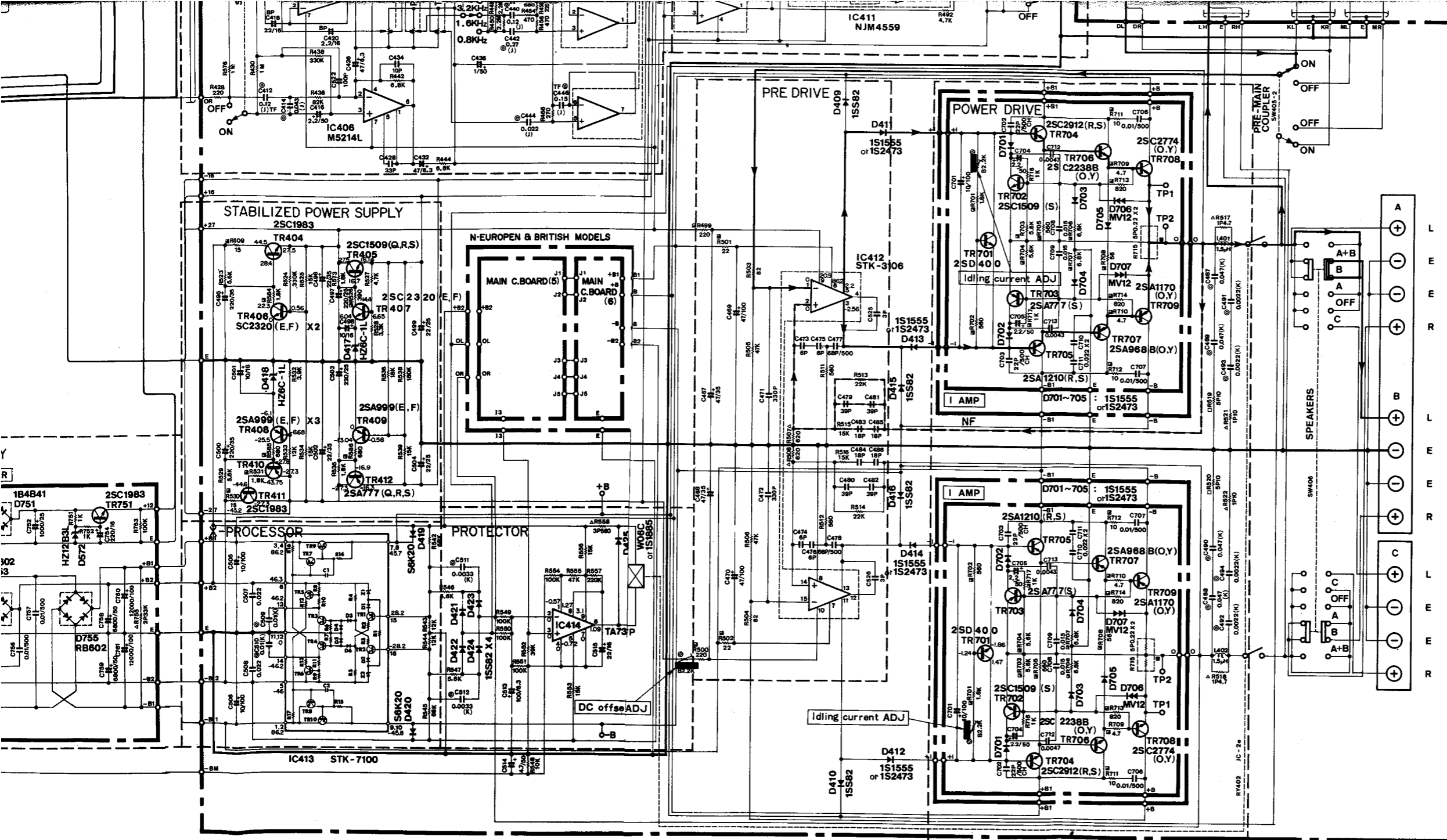

* All voltages measured with a 10MΩ/V DC electric Volt meter, no-signal condition.
BAND SELECT BUTTONS → FM
RX MODE → Auto
MUTING → ON
 The voltages in the tuner section are measured at FM reception mode.
 Only the voltages at TR113 ~ TR124, IC105 and 107 are measured at AM reception mode.
 * Schematic Diagram is subject change without notice.

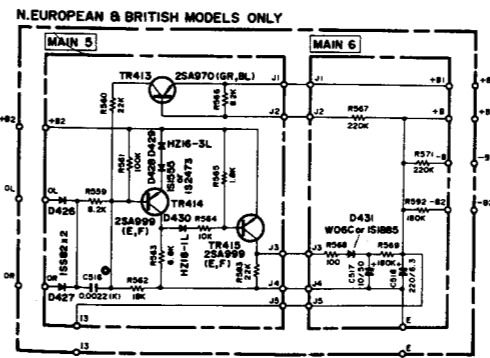

AREA	★ RESISTOR				★ FUSE
	R134	R135, 136	R166	R630	
U.S.A. & CANADIAN	22K	270P	100K	22K	F75 I
GENERAL	22K	270P	100K	—	T1.0A250V
BRITISH	22K	—	100K	—	T800mA250V
AUSTRALIAN	22K	—	100K	—	T1.0A250V
N. EUROPEAN	12K	—	47K	—	T800mA250V

CAUTION: *Connected in the North European and British models only.

6

7

8

9

10

TUNER

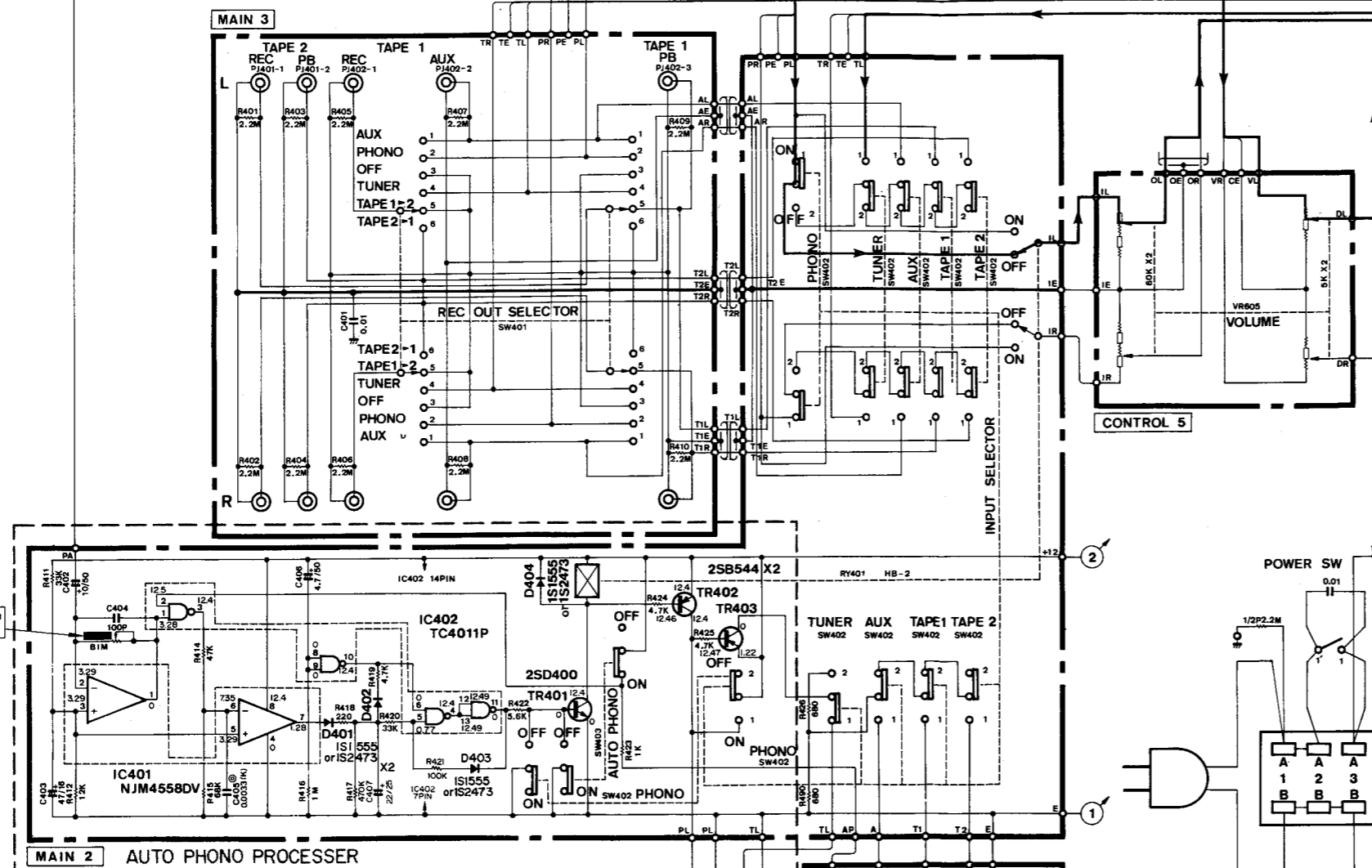

RESISTOR		CAPACITOR	
REMARKS	PARTS NAME	REMARKS	PARTS NAME
NO MARK	CARBON FILM RESISTOR	NO MARK	CERAMIC CAPACITOR
▲	METAL FILM RESISTOR	⊙	POLYESTER FILM CAPACITOR
△	METAL OXIDE FILM RESISTOR	●	SA CAPACITOR or SBL CAPACITOR
■	METAL PLATE RESISTOR	PS	PS CAPACITOR
□	CEMENT MOLDED RESISTOR		
▣	FLAME PROOF CARBON FILM RESISTOR		
⊗	SEMI VARIABLE RESISTOR		

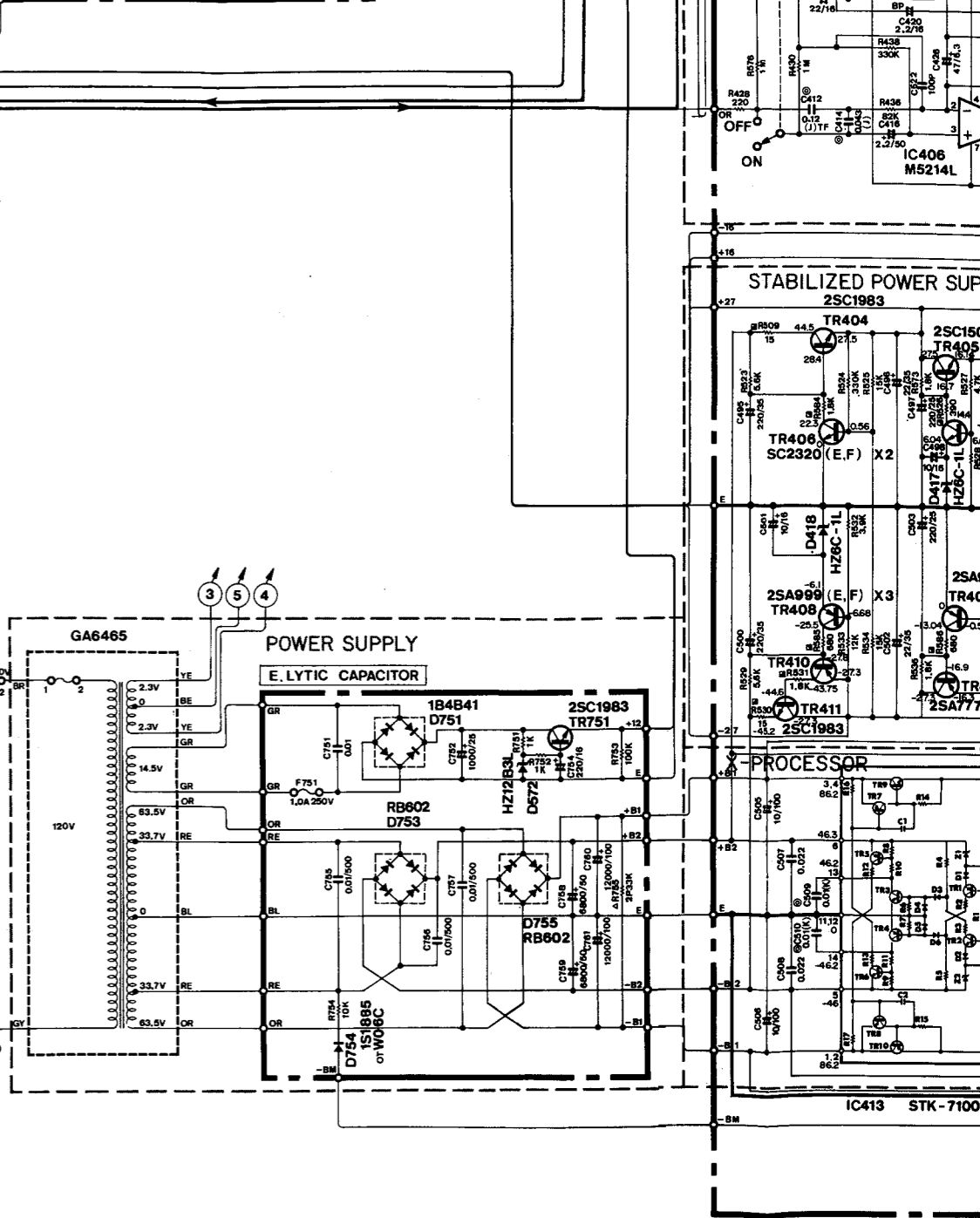

NOTE: Auto Phono Gain Control ADJ.
 Auto phono circuit switches at 0.3mV (100Hz) input to phono MM input by adjusting VR407 at the center position.
 The circuit switches at 0.15mV (100Hz) input to phono MM input by rotating VR407 full clockwise.

NORTH EUROPEAN MODEL

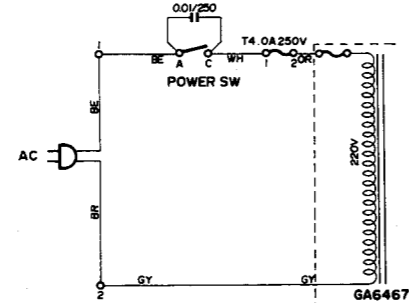

AUSTRALIAN & BRITISH MODELS

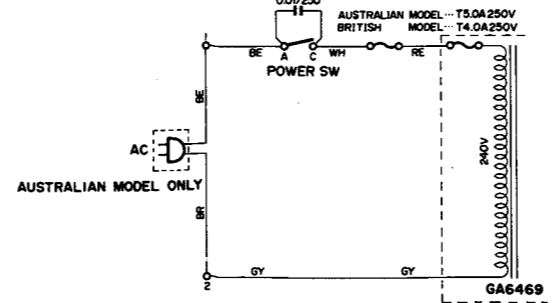

CANADIAN MODEL

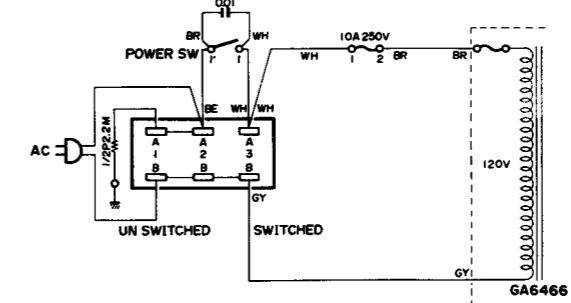

GENERAL MODEL

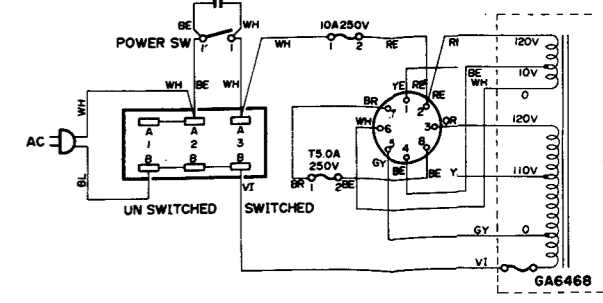

Tuner C. Board
TRANSISTOR, IC, VOLTAGE TABLE

T R No	F M				A M			
	Tuning mode(ST)	At Local	At DX	Detuned mode	Tuning mode	At Local	At DX	Detuned mode
101	B	0.6	0.6	0.6	0.6	0.24	0.24	
102	B	11.6	11.6	12.0	12.0	0.2	0.2	
103	B	-2.2	-2.2	-2.2	-1.7	-2.2	-1.72	
104	B	3.6	3.6	3.6	3.6	-0.6	-2.3	
105	B	11.0	11.0	11.0	11.0	0	0	
106	B	4.36	5.25	4.36	4.4	0.1	0.1	
107	B	10.05	9.2	11.1	11.1	0.0	0	
108	B	4.35	5.23	4.38	4.38			
109	B	11.1	9.2	11.1	11.1			
110	B	3.57	10.5	3.54	3.54	3.7	3.7	
111	B	4.1	4.2	4.08	4.08	4.1	4.1	
112	B	-1.7	-1.7	-1.7	0.07	-1.7	0.67	
113	B	0	0	0	0	0	0	
114	B	1.31	1.31	0.56	0.3	0	0	
115	B	4.3	4.2	10.9	12.0	0.2	0.2	
116	B	0.7	0.7	0	0	0.7	0.6	
117	B	9.09	9	9	9	0.01	0.01	
118	B	10.4	10.4	10.4	10.4	11.0	11.0	
119	B	4.2	4.2	4.2	4.2	4.3	4.3	
120	B	0.21	0.21	0.21	4.92	0.21	4.92	
121	B	4.3	4.3	4.3	4.3	4.3	4.3	
122	B	9.8	9.8	9.8	9.8	9.8	7.3	
123	B	4.2	4.2	4.2	4.2	4.2	4.2	
124	B	4.5	4.4	5.0	5.0	5.6	4.0	
125	B	12.4	12.4	12.4	12.4	0	0	
126	B	3.25	3.7	3.25	0.7	0.1	0.4	
127	B	-0.57	0	0.57	0	0	0	
128	B	0.1	0.69					
129	B	12.3	12.3	12.3	12.3	11.8	11.8	
130	B	12.5	12.5	12.5	12.5	12.6	12.6	
131	B	12.3	12.3	12.3	12.3	0.64	0.64	
132	B	11.6	11.6	11.6	11.6	12.4	12.4	
133	B	0.04	0.04	0.04	0.04	12.3	12.3	
134	B	9.1	9.1	9.1	8.7	9.1	8.7	
135	B	10.6	10.6	10.6	10.6	10.6	10.6	
136	B	12.5	12.5	12.5	12.5	12.5	12.5	
137	B	0.6						
139	B	0.04						
141	B	0						
143	B	4.32	4.32	4.32	0	0.7	0.7	

IC No	PIN No	F M	A M	F M (Mono)
101 (JPC577H)	1	5.26		
	2	1.8		
	3	2.19		
	4	0		
	5	9.09		
102 (JPC577H)	1	5.3		
	2	1.88		
	3	1.84		
	4	0		
	5	9.34		
103 (IG02920)	1	12.4		12.4
	2	4.28		4.28
	3	4.2		4.2
	4	4.37		4.37
	5	4.26		4.26
104 (4558DV)	1	12.49		12.49
	2	12.47		0
	3	12.48		12.48
	4	-1.71		8.07
	5	5.4		5.4
105 (LA-1245)	1	4.23		4.3
	2	4.22		2.98
	3	4.22		2.28
	4	0		2.64
	5	9.06		0
106 (MS214L)	1	-26.2		-26.2
	2	1.3		4.75
	3	1.3		4.7
	4	-27.3		-27.3
	5	2.7		12.38

IC No	PIN No	F M	A M	F M Detuned mode
107 (4558DV)	1	4.17	5.4	
	2	4.32	4.3	
	3	4.31	4.3	
	4	0	0	
	5	4.31	4.31	
	6	4.32	4.32	
	7	4.32	4.31	
	8	9.9	9.9	
	9	9.9	9.9	
	10	0	0	
	11	0.8	3.7	
	12	0	8.4	
	13	0.55	0.55	
	14	9.9	9.9	
108 (4069P)	1	12.4		12.4
	2	4.28		4.28
	3	4.2		4.2
	4	4.37		4.37
	5	4.26		4.26
	6	4.26		4.26
	7	4.27		4.27
	8	4.27		4.27
	9	4.26		4.26
	10	4.23		4.23
	11	0		0
	12	0.61		10.89
	13	4.74		4.64
	14	4.37		4.37
109 (IG03210)	1	12.49		12.49
	2	12.47		0
	3	12.48		12.48
	4	-1.71		8.07
	5	5.4		5.4
	6	12.4		12.4
	7	0		0
	8	0		10.8
	9	0.79		0.79
	10	10.48		10.6
	11	12.2		12.2
	12	0.99		0.55
	13	0		0
	14	2.0		1.1
15	3.22		0.68	
110 (NJM4559)	1	0		0
	2	0		0
	3	-16.3		0
	4	0		0
	5	0		0
	6	0		0
	7	0		0
	8	16.2		16.2
	9	27.9		27.9
	10	10.18		10.18
	11	0.68		0.68
	12	0		0
	13	-26.2		-26.2
	14	7.42		7.42
111 (MS214L)	1	-26.2		-26.2
	2	7.42		7.42
	3	7.42		7.42
	4	-27.3		-27.3
	5	-0.91		-0.91
	6	0		0
	7	27.6		27.6
	8	0		0
	9	-26.2		-26.2
	10	-0.26		-0.26
	11	-0.25		-0.25
	12	-26.2		-26.2
	13	-26.2		-26.2
	14	-27.32		-27.32
113 (MS214L)	1	-26.2		-26.2
	2	1.3		4.75
	3	1.3		4.7
	4	-27.3		-27.3
	5	2.7		12.38
	6	3.64		13.24
	7	27.58		27.58

IC BLOCK & SCHEMATIC DIAGRAM

STK3156

**NJM4560
NJM4558DV
NJM4559**

TOP VIEW

M5214L

TB7317P

μPC577H